

Following the Equator, Illustrated, v4

Mark Twain (Samuel Clemens)

Table of Contents

<u>Following the Equator, Illustrated, v4</u>	1
<u>Mark Twain (Samuel Clemens)</u>	2
<u>CONTENTS OF VOLUME 4</u>	12
<u>CHAPTER XXX</u>	13
<u>CHAPTER XXXI</u>	14
<u>CHAPTER XXXII</u>	15
<u>CHAPTER XXXIII</u>	16
<u>CHAPTER XXXIV</u>	17
<u>CHAPTER XXXV</u>	18
<u>CHAPTER XXXVI</u>	19
<u>CHAPTER XXXVII</u>	20
<u>CHAPTER XXXVIII</u>	21
<u>CHAPTER XXX</u>	22
<u>CHAPTER XXXI</u>	26
<u>CHAPTER XXXII</u>	32
<u>CHAPTER XXXIII</u>	39
<u>CHAPTER XXXIV</u>	44
<u>CHAPTER XXXV</u>	48
<u>CHAPTER XXXVI</u>	52
<u>A SWELTERING DAY IN AUSTRALIA</u>	57
<u>CHAPTER XXXVII</u>	59
<u>CHAPTER XXXVIII</u>	67

Following the Equator, Illustrated, v4

Mark Twain (Samuel Clemens)

This page copyright © 2002 Blackmask Online.
<http://www.blackmask.com>

- CHAPTER XXX.
 - CHAPTER XXXI.
 - CHAPTER XXXII.
 - CHAPTER XXXIII.
 - CHAPTER XXXIV.
 - CHAPTER XXXV.
 - CHAPTER XXXVI.

 - A SWELTERING DAY IN AUSTRALIA.

 - CHAPTER XXXVII.
 - CHAPTER XXXVIII.
-

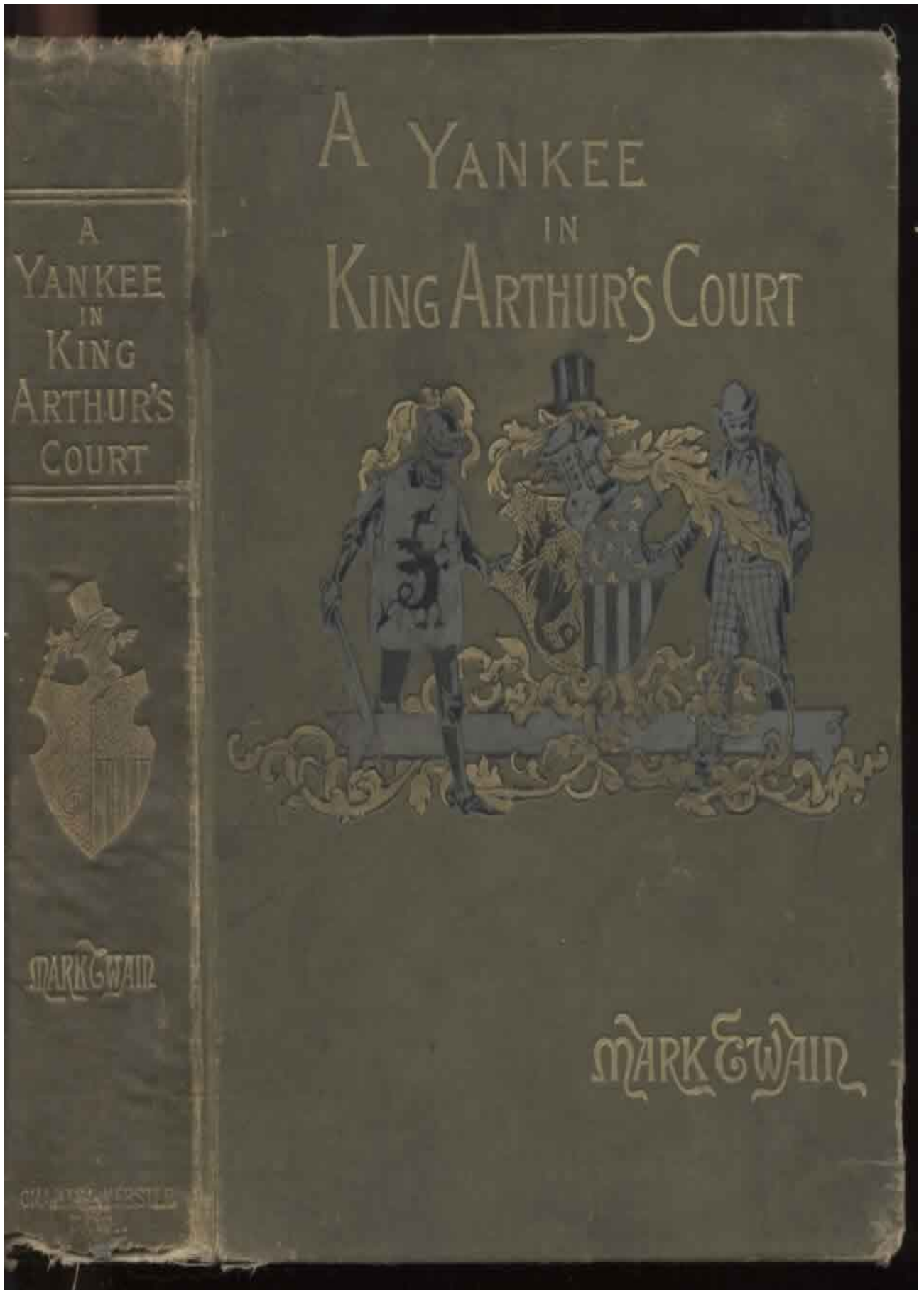

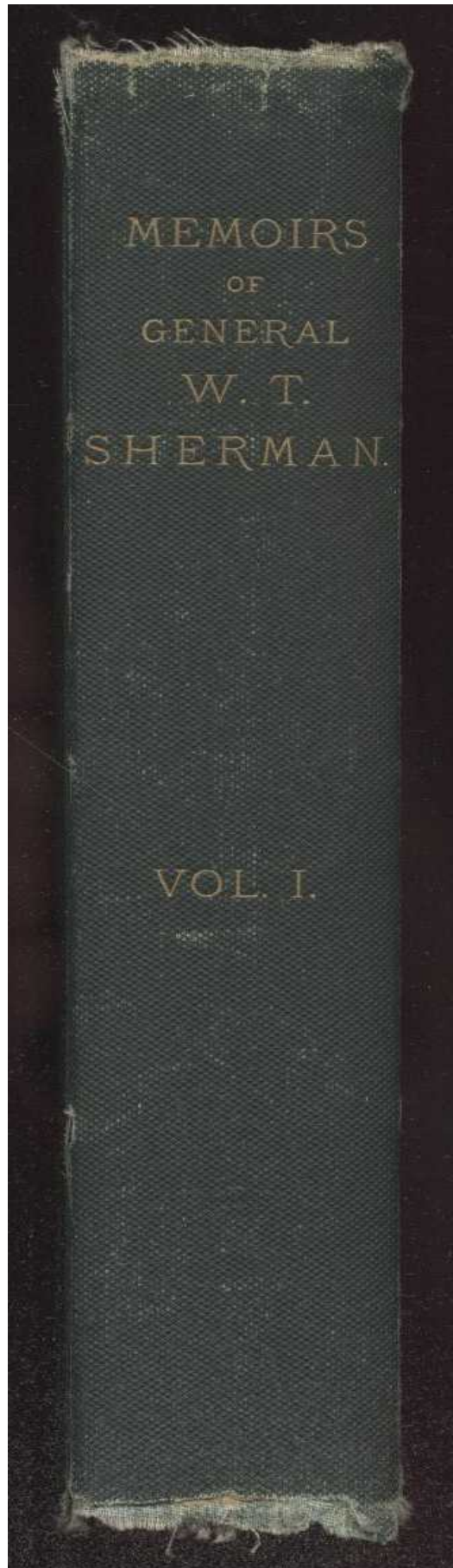

FOLLOWING
THE EQUATOR

A JOURNEY AROUND THE WORLD

BY

MARK TWAIN

SAMUEL L. CLEMENS





Be good + you will be lonesome.

Mark Twain

THIS BOOK
Is Affectionately Inscribed to
MY YOUNG FRIEND
HARRY ROGERS,
WITH RECOGNITION
OF WHAT HE IS, AND APPREHENSION OF WHAT HE MAY BECOME
UNLESS HE FORM HIMSELF A LITTLE MORE CLOSELY
UPON THE MODEL OF
THE AUTHOR.

THE PUDD'NHEAD MAXIMS.



THESE WISDOMS ARE FOR THE LURING OF YOUTH TOWARD
HIGH MORAL ALTITUDES. THE AUTHOR DID NOT
GATHER THEM FROM PRACTICE, BUT FROM
OBSERVATION. TO BE GOOD IS NOBLE;
BUT TO SHOW OTHERS HOW
TO BE GOOD IS NOBLER
AND NO TROUBLE.

Following the Equator, Illustrated, v4

CONTENTS OF VOLUME 4.

CHAPTER XXX.

Arrival at Bluff, N. Z.—Where the Rabbit Plague Began—The Natural Enemy of the Rabbit—Dunedin—A
Lovely Town—Visit to Dr. Hockin—His Museum— A Liquified Caterpillar—The Unperfected Tape
Worm—The Public Museum and Picture

CHAPTER XXXI.

The Express Train—"A Hell of a Hotel at Maryborough"—Clocks and Bells—Railroad Service.

CHAPTER XXXII.

Description of the Town of Christ Church—A Fine Museum—Jade-stone Trinkets—The Great Man—The First Maori in New Zealand—Women Voters— "Person" in New Zealand Law Includes Woman—Taming an Ornithorhynchus— A Voyage in the 'Flora' from Lyttelton—Cattle Stalls for Everybody— A Wonderful Time.

CHAPTER XXXIII.

The Town of Nelson—"The Mongatapu Murders," the Great Event of the Town —Burgess' Confession—Summit of Mount Eden—Rotorua and the Hot Lakes and Geysers—Thermal Springs District—Kauri Gum—Tangariwa Mountains

CHAPTER XXXIV.

The Bay of Gisborne—Taking in Passengers by the Yard Arm—The Green Ballarat Fly—False Teeth—From Napier to Hastings by the Ballarat Fly Train—Kauri Trees—A Case of Mental Telegraphy

CHAPTER XXXV.

Fifty Miles in Four Hours—Comfortable Cars—Town of Waunganui—Plenty of Maoris—On the Increase—Compliments to the Maoris—The Missionary Ways all Wrong—The Tabu among the Maoris—A Mysterious Sign—Curious War—monuments—Wellington

CHAPTER XXXVI.

The Poems of Mrs. Moore—The Sad Fate of William Upson—A Fellow Traveler Imitating the Prince of Wales—A Would-be Dude—Arrival at Sydney— Curious Town Names with Poem

CHAPTER XXXVII.

From Sydney for Ceylon—A Lascar Crew—A Fine Ship—Three Cats and a Basket of Kittens—Dinner Conversations—Veuve Cliquot Wine—At Anchor in King George's Sound Albany Harbor—More Cats—A Vulture on Board—Nearing the Equator again—Dressing for Dinner—Ceylon, Hotel Bristol—Servant Brampy—A Feminine Man—Japanese Jinriksha or Cart—Scenes in Ceylon—A Missionary School—Insincerity of Clothes

CHAPTER XXXVIII.

Steamer Rosettes to Bombay—Limes 14 cents a Barrel—Bombay, a Bewitching City—Descriptions of People and Dress—Woman as a Road Decoration— India, the Land of Dreams and Romance—Fourteen Porters to Carry Baggage— Correcting a Servant—Killing a Slave—Arranging a Bedroom—Three Hours' Work and a Terrible Racket—The Bird of Birds, the Indian Crow

CHAPTER XXX.

Nature makes the locust with an appetite for crops; man would have made him with an appetite for sand.

—Pudd'nhead Wilson's New Calendar.

We spent part of an afternoon and a night at sea, and reached Bluff, in New Zealand, early in the morning. Bluff is at the bottom of the middle island, and is away down south, nearly forty–seven degrees below the equator. It lies as far south of the line as Quebec lies north of it, and the climates of the two should be alike; but for some reason or other it has not been so arranged. Quebec is hot in the summer and cold in the winter, but Bluff's climate is less intense; the cold weather is not very cold, the hot weather is not very hot; and the difference between the hottest month and the coldest is but 17 degrees Fahrenheit.

In New Zealand the rabbit plague began at Bluff. The man who introduced the rabbit there was banqueted and lauded; but they would hang him, now, if they could get him. In England the natural enemy of the rabbit is detested and persecuted; in the Bluff region the natural enemy of the rabbit is honored, and his person is sacred. The rabbit's natural enemy in England is the poacher, in Bluff its natural enemy is the stoat, the weasel, the ferret, the cat, and the mongoose. In England any person below the Heir who is caught with a rabbit in his possession must satisfactorily explain how it got there, or he will suffer fine and imprisonment, together with extinction of his peerage; in Bluff, the cat found with a rabbit in its possession does not have to explain—everybody looks the other way; the person caught noticing would suffer fine and imprisonment, with extinction of peerage. This is a sure way to undermine the moral fabric of a cat. Thirty years from now there will not be a moral cat in New Zealand. Some think there is none there now. In England the poacher is watched, tracked, hunted—he dare not show his face; in Bluff the cat, the weasel, the stoat, and the mongoose go up and down, whither they will, unmolested. By a law of the legislature, posted where all may read, it is decreed that any person found in possession of one of these creatures (dead) must satisfactorily explain the circumstances or pay a fine of not less than L5, nor more than L20. The revenue from this source is not large. Persons who want to pay a hundred dollars for a dead cat are getting rarer and rarer every day. This is bad, for the revenue was to go to the endowment of a University. All governments are more or less short-sighted: in England they fine the poacher, whereas he ought to be banished to New Zealand. New Zealand would pay his way, and give him wages.

It was from Bluff that we ought to have cut across to the west coast and visited the New Zealand Switzerland, a land of superb scenery, made up of snowy grandeurs, anal mighty glaciers, and beautiful lakes; and over there, also, are the wonderful rivals of the Norwegian and Alaskan fiords; and for neighbor, a waterfall of 1,900 feet; but we were obliged to postpone the trip to some later and indefinite time.



November 6. A lovely summer morning; brilliant blue sky. A few miles out from Invercargill, passed through vast level green expanses snowed over with sheep. Fine to see. The green, deep and very vivid sometimes; at other times less so, but delicate and lovely. A passenger reminds me that I am in "the England of the Far South."

Dunedin, same date. The town justifies Michael Davitt's praises. The people are Scotch. They stopped here on their way from home to heaven— thinking they had arrived. The population is stated at 40,000, by Malcolm Ross, journalist; stated by an M. P. at 60,000. A journalist cannot lie.

To the residence of Dr. Hockin. He has a fine collection of books relating to New Zealand; and his house is a museum of Maori art and antiquities. He has pictures and prints in color of many native chiefs of the past—some of them of note in history. There is nothing of the savage in the faces; nothing could be finer than these men's features, nothing more intellectual than these faces, nothing more masculine, nothing nobler than their aspect. The aboriginals of Australia and Tasmania looked the savage, but these chiefs looked like Roman patricians. The tattooing in these portraits ought to suggest the savage, of course, but it does not. The designs are so flowing and graceful and beautiful that they are a most satisfactory decoration. It takes but fifteen minutes to get reconciled to the tattooing, and but fifteen more to perceive that it is just the thing. After that, the undecorated European face is unpleasant and ignoble.



CANNIBALISM IN THE CARS.

I VISITED St Louis lately, and on my way west, after changing cars at Terre Haute, Indiana, a mild, benevolent-looking gentleman of about forty-five, or may be fifty, came in at one of the way-stations and sat down beside me. We talked together pleasantly on various subjects for an hour, perhaps, and I found him exceedingly intelligent and entertaining. When he learned that I was from Washington, he immediately began to ask questions about various public men, and about Congressional affairs; and I saw very shortly that I was conversing with a man who was perfectly familiar with the ins and outs of political life at the Capital, even to the ways and

Dr. Hockiu gave us a ghastly curiosity—a lignified caterpillar with a plant growing out of the back of its neck—a plant with a slender stem 4 inches high. It happened not by accident, but by design—Nature's design. This caterpillar was in the act of loyally carrying out a law inflicted upon him by Nature—a law purposely inflicted upon him to get him into trouble—a law which was a trap; in pursuance of this law he made the proper preparations for turning himself into a night-moth; that is to say, he dug a little trench, a little grave, and then

stretched himself out in it on his stomach and partially buried himself—then Nature was ready for him. She blew the spores of a peculiar fungus through the air with a purpose. Some of them fell into a crease in the back of the caterpillar's neck, and began to sprout and grow—for there was soil there—he had not washed his neck. The roots forced themselves down into the worm's person, and rearward along through its body, sucking up the creature's juices for sap; the worm slowly died, and turned to wood. And here he was now, a wooden caterpillar, with every detail of his former physique delicately and exactly preserved and perpetuated, and with that stem standing up out of him for his monument—monument commemorative of his own loyalty and of Nature's unfair return for it.

Nature is always acting like that. Mrs. X. said (of course) that the caterpillar was not conscious and didn't suffer. She should have known better. No caterpillar can deceive Nature. If this one couldn't suffer, Nature would have known it and would have hunted up another caterpillar. Not that she would have let this one go, merely because it was defective. No. She would have waited and let him turn into a night-moth; and then fried him in the candle.

Nature cokes a fish's eyes over with parasites, so that it shan't be able to avoid its enemies or find its food. She sends parasites into a star-fish's system, which clog up its prongs and swell them and make them so uncomfortable that the poor creature delivers itself from the prong to ease its misery; and presently it has to part with another prong for the sake of comfort, and finally with a third. If it re-grows the prongs, the parasite returns and the same thing is repeated. And finally, when the ability to reproduce prongs is lost through age, that poor old star-fish can't get around any more, and so it dies of starvation.

In Australia is prevalent a horrible disease due to an "unperfected tapeworm." Unperfected—that is what they call it, I do not know why, for it transacts business just as well as if it were finished and frescoed and gilded, and all that.

November 9. To the museum and public picture gallery with the president of the Society of Artists. Some fine pictures there, lent by the S. of A. several of them they bought, the others came to them by gift. Next, to the gallery of the S. of A.—annual exhibition—just opened. Fine. Think of a town like this having two such collections as this, and a Society of Artists. It is so all over Australasia. If it were a monarchy one might understand it. I mean an absolute monarchy, where it isn't necessary to vote money, but take it. Then art flourishes. But these colonies are republics—republics with a wide suffrage; voters of both sexes, this one of New Zealand. In republics, neither the government nor the rich private citizen is much given to propagating art. All over Australasia pictures by famous European artists are bought for the public galleries by the State and by societies of citizens. Living citizens—not dead ones. They rob themselves to give, not their heirs. This S. of A. here owns its buildings built it by subscription.

CHAPTER XXXI.

The spirit of wrath—not the words—is the sin; and the spirit of wrath is cursing. We begin to swear before we can talk.

—Pudd'nhead Wilson's New Calendar.

November 11. On the road. This train-express goes twenty and one-half miles an hour, schedule time; but it is fast enough, the outlook upon sea and land is so interesting, and the cars so comfortable. They are not English, and not American; they are the Swiss combination of the two. A narrow and railed porch along the side, where a person can walk up and down. A lavatory in each car. This is progress; this is nineteenth-century spirit. In New Zealand, these fast expresses run twice a week. It is well to know this if you want to be a bird and fly through the country at a 20-mile gait; otherwise you may start on one of the five wrong days, and then you will get a train that can't overtake its own shadow.

By contrast, these pleasant cars call to mind the branch-road cars at Maryborough, Australia, and the passengers' talk about the branch-road and the hotel.

Somewhere on the road to Maryborough I changed for a while to a smoking-carriage. There were two gentlemen there; both riding backward, one at each end of the compartment. They were acquaintances of each other. I sat down facing the one that sat at the starboard window. He had a good face, and a friendly look, and I judged from his dress that he was a dissenting minister. He was along toward fifty. Of his own motion he struck a match, and shaded it with his hand for me to light my cigar. I take the rest from my diary:

In order to start conversation I asked him something about Maryborough. He said, in a most pleasant—even musical voice, but with quiet and cultured decision:

"It's a charming town, with a hell of a hotel."

I was astonished. It seemed so odd to hear a minister swear out loud. He went placidly on:

"It's the worst hotel in Australia. Well, one may go further, and say in Australasia."

Aerospace Employment (1964-71)

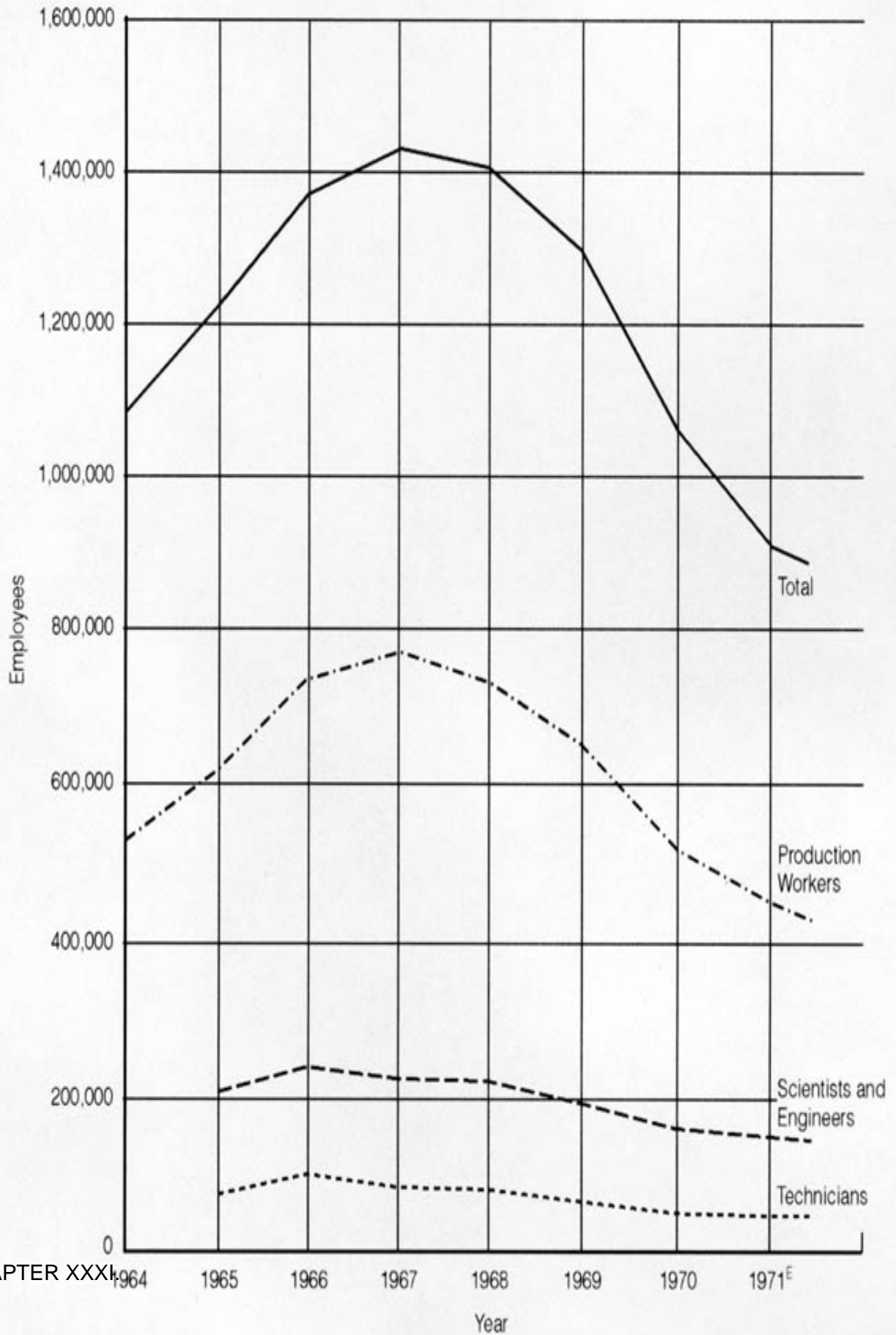

"Bad beds?"

"No—none at all. Just sand—bags."

"The pillows, too?"

"Yes, the pillows, too. Just sand. And not a good quality of sand. It packs too hard, and has never been screened. There is too much gravel in it. It is like sleeping on nuts."

"Isn't there any good sand?"

"Plenty of it. There is as good bed—sand in this region as the world can furnish. Aerated sand—and loose; but they won't buy it. They want something that will pack solid, and petrify."

"How are the rooms?"

"Eight feet square; and a sheet of iced oil—cloth to step on in the morning when you get out of the sand—quarry."

"As to lights?"

"Coal—oil lamp."

"A good one?"

"No. It's the kind that sheds a gloom."

"I like a lamp that burns all night."

"This one won't. You must blow it out early."

"That is bad. One might want it again in the night. Can't find it in the dark."

"There's no trouble; you can find it by the stench."

"Wardrobe?"

"Two nails on the door to hang seven suits of clothes on if you've got them."

"Bells?"

"There aren't any."

"What do you do when you want service?"

"Shout. But it won't fetch anybody."

"Suppose you want the chambermaid to empty the slopjar?"

"There isn't any slop—jar. The hotels don't keep them. That is, outside of Sydney and Melbourne."

"Yes, I knew that. I was only talking. It's the oddest thing in Australia. Another thing: I've got to get up in the dark, in the morning, to take the 5 o'clock train. Now if the boots——"

"There isn't any."

"Well, the porter."

"There isn't any."

"But who will call me?"

"Nobody. You'll call yourself. And you'll light yourself, too. There'll not be a light burning in the halls or anywhere. And if you don't carry a light, you'll break your neck."

"But who will help me down with my baggage?"

"Nobody. However, I will tell you what to do. In Maryborough there's an American who has lived there half a lifetime; a fine man, and prosperous and popular. He will be on the lookout for you; you won't have any trouble. Sleep in peace; he will rout you out, and you will make your train. Where is your manager?"

"I left him at Ballarat, studying the language. And besides, he had to go to Melbourne and get us ready for New Zealand. I've not tried to pilot myself before, and it doesn't look easy."

"Easy! You've selected the very most difficult piece of railroad in Australia for your experiment. There are twelve miles of this road which no man without good executive ability can ever hope—tell me, have you good executive ability? first—rate executive ability?"

"I—well, I think so, but——"

"That settles it. The tone of—oh, you wouldn't ever make it in the world. However, that American will point you right, and you'll go. You've got tickets?"

"Yes—round trip; all the way to Sydney."

"Ah, there it is, you see! You are going in the 5 o'clock by Castlemaine—twelve miles—instead of the 7.15 by Ballarat—in order to save two hours of fooling along the road. Now then, don't interrupt—let me have the floor. You're going to save the government a deal of hauling, but that's nothing; your ticket is by Ballarat, and it isn't good over that twelve miles, and so——"

"But why should the government care which way I go?"

"Goodness knows! Ask of the winds that far away with fragments strewed the sea, as the boy that stood on the burning deck used to say. The government chooses to do its railway business in its own way, and it doesn't know as much about it as the French. In the beginning they tried idiots; then they imported the French—which was going backwards, you see; now it runs the roads itself—which is going backwards again, you see. Why, do you know, in order to curry favor with the voters, the government puts down a road wherever anybody wants it—anybody that owns two sheep and a dog; and by consequence we've got, in the colony of Victoria, 800 railway stations, and the business done at eighty of them doesn't foot up twenty shillings a week."

"Five dollars? Oh, come!"

"It's true. It's the absolute truth."

"Why, there are three or four men on wages at every station."

"I know it. And the station-business doesn't pay for the sheep-dip to sanctify their coffee with. It's just as I say. And accommodating? Why, if you shake a rag the train will stop in the midst of the wilderness to pick you up. All that kind of politics costs, you see. And then, besides, any town that has a good many votes and wants a fine station, gets it. Don't you overlook that Maryborough station, if you take an interest in governmental curiosities. Why, you can put the whole population of Maryborough into it, and give them a sofa apiece, and have room for more. You haven't fifteen stations in America that are as big, and you probably haven't five that are half as fine. Why, it's perfectly elegant. And the clock! Everybody will show you the clock. There isn't a station in Europe that's got such a clock. It doesn't strike—and that's one mercy. It hasn't any bell; and as you'll have cause to remember, if you keep your reason, all Australia is simply bedammed with bells."

midnight:
clang—clang—
clang—clang!
 hello, what's
 Oh, I see—
 ed by the
 wouldn't
 could scare
 of course,
 and run
 at a loss,
 stations
 like Mary-
 at another
 the govern-
 has got to econ-
 somewhere,
 it? Very well—
 the rolling stock!
 where they save the
 Why, that train from
 ough will consist of
 freight-cars and
 senger-kennels;
 cheap, poor,
 shabby, slovenly;
 no drinking water,
 no sanitary arrange-
 ments, every imaginable
 inconvenience; and slow?—
 oh, the gait of cold molasses;
 no airbrake, no engine, and the all

clang—clang—clang—clang—
clang—clang—clang—clang—
 —and, by that time you're—
 all this excitement about?
 a runaway—scar-
 train; why, you
 think *this* train
 anything. Well,
 when they build
 eighty stations
 and a lot of palace-
 and clocks
 borough's
 loss,
 ment
 omize
 hasn't
 lookat
 That's
 money.
 Marybor-
 eighteen
 two pas-



On every quarter-hour, night and day, they jingle a tiresome chime of half a dozen notes—all the clocks in town at once, all the clocks in Australasia at once, and all the very same notes; first, downward scale: mi, re, do, sol—then upward scale: sol, si, re, do—down again: mi, re, do, sol—up again: sol, si, re, do—then the clock—say at midnight clang—clang—clang—clang—clang—clang—clang—clang—clang— and, by that time you're—hello, what's all this excitement about? a runaway—scared by the train; why, you think this train could scare anything. Well, when they build eighty stations at a loss and a lot of palace-stations and clocks like Maryborough's at another loss, the government has got to economize somewhere hasn't it? Very well look at the rolling stock. That's where they save the money. Why, that train from Maryborough will consist of eighteen freight-cars and two passenger-kennels; cheap, poor, shabby, slovenly; no drinking water, no sanitary arrangements, every imaginable inconvenience; and slow?—oh, the gait of cold molasses; no air-brake, no springs, and they'll jolt your head off every time they start or stop. That's where they make their little economies, you see. They spend tons of money to house you palatially while you wait fifteen minutes for a train, then degrade you to six hours' convict-transportation to get the foolish outlay back. What a rational man really needs is discomfort while he's waiting, then his journey in a nice train would be a grateful change. But no, that would be common sense—and out of place in a government. And then, besides, they save in that other little detail, you know—repudiate their own tickets, and collect a poor little illegitimate extra shilling out of you for that twelve miles, and——"

"Well, in any case——"

"Wait—there's more. Leave that American out of the account and see what would happen. There's nobody on hand to examine your ticket when you arrive. But the conductor will come and examine it when the train is ready to start. It is too late to buy your extra ticket now; the train can't wait, and won't. You must climb out."

"But can't I pay the conductor?"

"No, he is not authorized to receive the money, and he won't. You must climb out. There's no other way. I tell you, the railway management is about the only thoroughly European thing here—continentally European I mean, not English. It's the continental business in perfection; down fine. Oh, yes, even to the peanut-commerce of weighing baggage."

The train slowed up at his place. As he stepped out he said:

"Yes, you'll like Maryborough. Plenty of intelligence there. It's a charming place—with a hell of a hotel."

Then he was gone. I turned to the other gentleman:

"Is your friend in the ministry?"

"No—studying for it."

CHAPTER XXXII.

The man with a new idea is a Crank until the idea succeeds.

—Pudd'nhead Wilson's New Calendar.

It was Junior England all the way to Christchurch—in fact, just a garden. And Christchurch is an English town, with an English-park annex, and a winding English brook just like the Avon—and named the Avon; but from a man, not from Shakespeare's river. Its grassy banks are bordered by the stateliest and most impressive weeping willows to be found in the world, I suppose. They continue the line of a great ancestor; they were grown from sprouts of the willow that sheltered Napoleon's grave in St. Helena. It is a settled old community, with all the serenities, the graces, the conveniences, and the comforts of the ideal home-life. If it had an established Church and social inequality it would be England over again with hardly a lack.

In the museum we saw many curious and interesting things; among others a fine native house of the olden time, with all the details true to the facts, and the showy colors right and in their proper places. All the details: the fine mats and rugs and things; the elaborate and wonderful wood carvings—wonderful, surely, considering who did them wonderful in design and particularly in execution, for they were done with admirable sharpness and exactness, and yet with no better tools than flint and jade and shell could furnish; and the totem-posts were there, ancestor above ancestor, with tongues protruded and hands clasped comfortably over bellies containing other people's ancestors—grotesque and ugly devils, every one, but lovingly carved, and ably; and the stuffed natives were present, in their proper places, and looking as natural as life; and the housekeeping utensils were there, too, and close at hand the carved and finely ornamented war canoe.

And we saw little jade gods, to hang around the neck—not everybody's, but sacred to the necks of natives of rank. Also jade weapons, and many kinds of jade trinkets—all made out of that excessively hard stone without the help of any tool of iron. And some of these things had small round holes bored through them—nobody knows how it was done; a mystery, a lost art. I think it was said that if you want such a hole bored in a piece of jade now, you must send it to London or Amsterdam where the lapidaries are.

And we saw little jade gods, to hang around the neck — not everybody's, but sacred to the necks of natives of rank. Also jade weapons, and many kinds of jade trinkets — all made out of that excessively hard stone without the help of any tool of iron. And some of these things had small round holes bored through them — nobody knows how it was done; a mystery, a lost art. I think it was said that if you want such a hole bored in a piece of jade now, you must send it to London or Amsterdam where the lapidaries are.



CARVED CANOE PROW.

Also we saw a complete skeleton of the giant Moa. It stood ten feet high, and must have been a sight to look at when it was a living bird. It was a kicker, like the ostrich; in fight it did not use its beak, but its foot. It must have been a convincing kind of kick.

If a person had his back to the bird and did not see who it was that did it, he would think he had been kicked by a wind-mill.

Also we saw a complete skeleton of the giant Moa. It stood ten feet high, and must have been a sight to look at when it was a living bird. It was a kicker, like the ostrich; in fight it did not use its beak, but its foot. It must have been a convincing kind of kick. If a person had his back to the bird and did not see who it was that did it, he would think he had been kicked by a wind-mill.

There must have been a sufficiency of moas in the old forgotten days when his breed walked the earth. His bones are found in vast masses, all crammed together in huge graves. They are not in caves, but in the ground. Nobody knows how they happened to get concentrated there. Mind, they are bones, not fossils. This means that

the moa has not been extinct very long. Still, this is the only New Zealand creature which has no mention in that otherwise comprehensive literature, the native legends. This is a significant detail, and is good circumstantial evidence that the moa has been extinct 500 years, since the Maori has himself—by tradition—been in New Zealand since the end of the fifteenth century. He came from an unknown land—the first Maori did—then sailed back in his canoe and brought his tribe, and they removed the aboriginal peoples into the sea and into the ground and took the land. That is the tradition. That that first Maori could come, is understandable, for anybody can come to a place when he isn't trying to; but how that discoverer found his way back home again without a compass is his secret, and he died with it in him. His language indicates that he came from Polynesia. He told where he came from, but he couldn't spell well, so one can't find the place on the map, because people who could spell better than he could, spelt the resemblance all out of it when they made the map. However, it is better to have a map that is spelt right than one that has information in it.

In New Zealand women have the right to vote for members of the legislature, but they cannot be members themselves. The law extending the suffrage to them event into effect in 1893. The population of Christchurch (census of 1891) was 31,454. The first election under the law was held in November of that year. Number of men who voted, 6,313; number of women who voted, 5,989. These figures ought to convince us that women are not as indifferent about politics as some people would have us believe. In New Zealand as a whole, the estimated adult female population was 139,915; of these 109,461 qualified and registered their names on the rolls 78.23 per cent. of the whole. Of these, 90,290 went to the polls and voted—85.18 per cent. Do men ever turn out better than that—in America or elsewhere? Here is a remark to the other sex's credit, too—I take it from the official report:

"A feature of the election was the orderliness and sobriety of the people. Women were in no way molested."

At home, a standing argument against woman suffrage has always been that women could not go to the polls without being insulted. The arguments against woman suffrage have always taken the easy form of prophecy. The prophets have been prophesying ever since the woman's rights movement began in 1848—and in forty-seven years they have never scored a hit.

Men ought to begin to feel a sort of respect for their mothers and wives and sisters by this time. The women deserve a change of attitude like that, for they have wrought well. In forty-seven years they have swept an imposingly large number of unfair laws from the statute books of America. In that brief time these serfs have set themselves free essentially. Men could not have done so much for themselves in that time without bloodshed—at least they never have; and that is argument that they didn't know how. The women have accomplished a peaceful revolution, and a very beneficent one; and yet that has not convinced the average man that they are intelligent, and have courage and energy and perseverance and fortitude. It takes much to convince the average man of anything; and perhaps nothing can ever make him realize that he is the average woman's inferior—yet in several important details the evidences seems to show that that is what he is. Man has ruled the human race from the beginning—but he should remember that up to the middle of the present century it was a dull world, and ignorant and stupid; but it is not such a dull world now, and is growing less and less dull all the time. This is woman's opportunity—she has had none before. I wonder where man will be in another forty-seven years?

In the New Zealand law occurs this: "The word person wherever it occurs throughout the Act includes woman."

That is promotion, you see. By that enlargement of the word, the matron with the garnered wisdom and experience of fifty years becomes at one jump the political equal of her callow kid of twenty-one. The white population of the colony is 626,000, the Maori population is 42,000. The whites elect seventy members of the House of Representatives, the Maoris four. The Maori women vote for their four members.

November 16. After four pleasant days in Christchurch, we are to leave at midnight to-night. Mr. Kinsey gave me an ornithorhynchus, and I am taming it.

Sunday, 17th. Sailed last night in the Flora, from Lyttelton.

So we did. I remember it yet. The people who sailed in the Flora that night may forget some other things if they live a good while, but they will not live long, enough to forget that. The Flora is about the equivalent of a cattle-scow; but when the Union Company find it inconvenient to keep a contract and lucrative to break it, they smuggle her into passenger service, and "keep the change."

They give no notice of their projected depredation; you innocently buy tickets for the advertised passenger boat, and when you get down to Lyttelton at midnight, you find that they have substituted the scow. They have

plenty of good boats, but no competition—and that is the trouble. It is too late now to make other arrangements if you have engagements ahead.

It is a powerful company, it has a monopoly, and everybody is afraid of it—including the government's representative, who stands at the end of the stage—plank to tally the passengers and see that no boat receives a greater number than the law allows her to carry. This conveniently—blind representative saw the scow receive a number which was far in excess of its privilege, and winked a politic wink and said nothing. The passengers bore with meekness the cheat which had been put upon them, and made no complaint.

It was like being at home in America, where abused passengers act in just the same way. A few days before, the Union Company had discharged a captain for getting a boat into danger, and had advertised this act as evidence of its vigilance in looking after the safety of the passengers— for thugging a captain costs the company nothing, but when opportunity offered to send this dangerously overcrowded tub to sea and save a little trouble and a tidy penny by it, it forgot to worry about the passenger's safety.

The first officer told me that the Flora was privileged to carry 125 passengers. She must have had all of 200 on board. All the cabins were full, all the cattle—stalls in the main stable were full, the spaces at the heads of companionways were full, every inch of floor and table in the swill—room was packed with sleeping men and remained so until the place was required for breakfast, all the chairs and benches on the hurricane deck were occupied, and still there were people who had to walk about all night!

If the Flora had gone down that night, half of the people on board would have been wholly without means of escape.

The owners of that boat were not technically guilty of conspiracy to commit murder, but they were morally guilty of it.

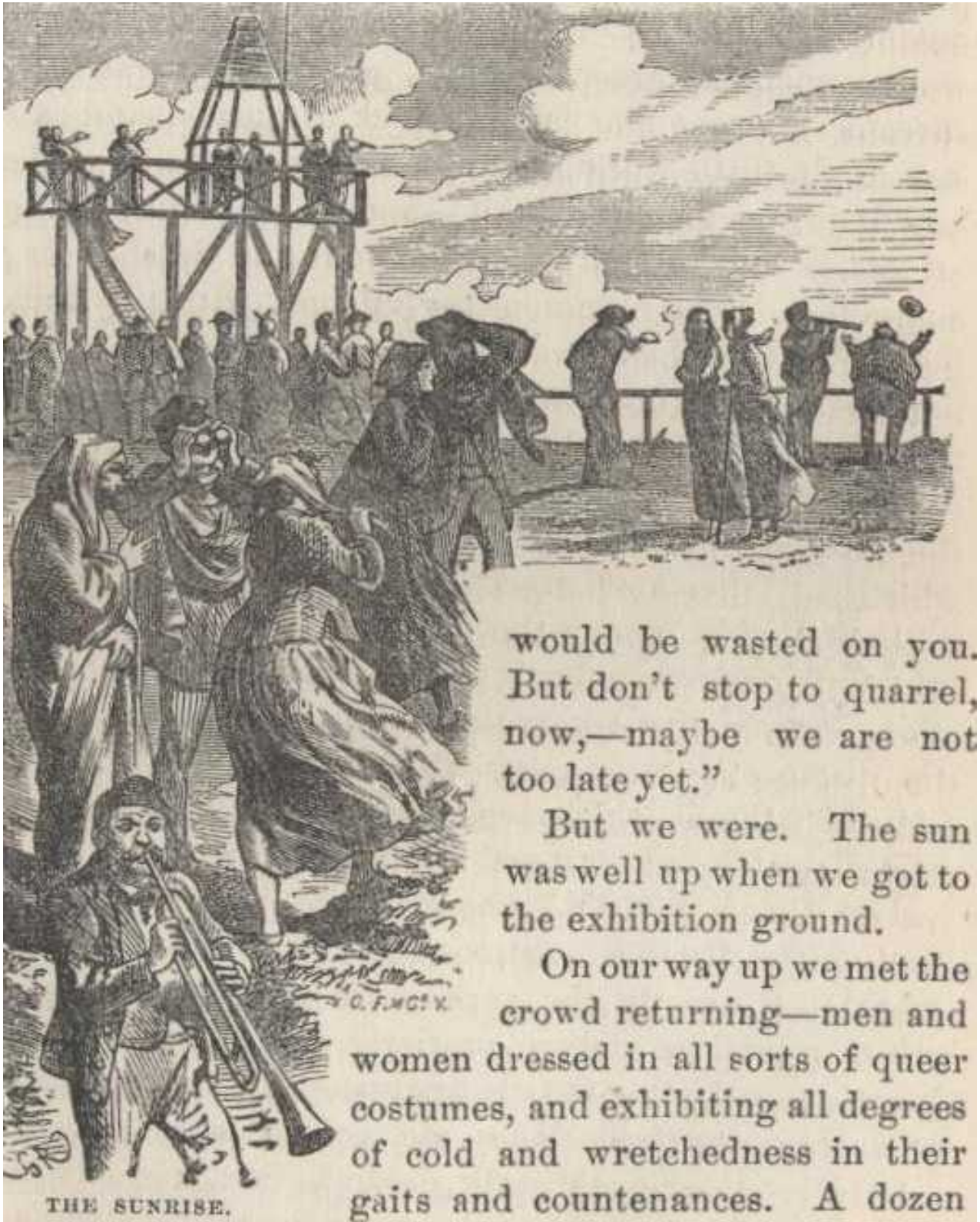

THE SUNRISE.

would be wasted on you. But don't stop to quarrel, now,—maybe we are not too late yet."

But we were. The sun was well up when we got to the exhibition ground.

On our way up we met the crowd returning—men and women dressed in all sorts of queer costumes, and exhibiting all degrees of cold and wretchedness in their gaits and countenances. A dozen

I had a cattle-stall in the main stable—a cavern fitted up with a long double file of two-storied bunks, the files separated by a calico partition—twenty men and boys on one side of it, twenty women and girls on the other. The place was as dark as the soul of the Union Company, and smelt like a kennel. When the vessel got out into the heavy seas and began to pitch and wallow, the cavern prisoners became immediately seasick, and then the peculiar results that ensued laid all my previous experiences of the kind well away in the shade. And the wails, the groans, the cries, the shrieks, the strange ejaculations—it was wonderful.

The women and children and some of the men and boys spent the night in that place, for they were too ill to leave it; but the rest of us got up, by and by, and finished the night on the hurricane-deck.

That boat was the foulest I was ever in; and the smell of the breakfast saloon when we threaded our way among the layers of steaming passengers stretched upon its floor and its tables was incomparable for efficiency.

A good many of us got ashore at the first way-port to seek another ship. After a wait of three hours we got good rooms in the Mahinapua, a wee little bridal-parlor of a boat—only 205 tons burthen; clean and comfortable; good service; good beds; good table, and no crowding. The seas danced her about like a duck, but she was safe and capable.

Next morning early she went through the French Pass—a narrow gateway of rock, between bold headlands—so narrow, in fact, that it seemed no wider than a street. The current tore through there like a mill-race, and the boat darted through like a telegram. The passage was made in half a minute; then we were in a wide place where noble vast eddies swept grandly round and round in shoal water, and I wondered what they would do with the little boat. They did as they pleased with her. They picked her up and flung her around like nothing and landed her gently on the solid, smooth bottom of sand—so gently, indeed, that we barely felt her touch it, barely felt her quiver when she came to a standstill. The water was as clear as glass, the sand on the bottom was vividly distinct, and the fishes seemed to be swimming about in nothing. Fishing lines were brought out, but before we could bait the hooks the boat was off and away again.



CHAPTER XXXIII.

Let us be grateful to Adam our benefactor. He cut us out of the "blessing of idleness," and won for us the "curse of labor."

—Pudd'nhead Wilson's New Calendar.

We soon reached the town of Nelson, and spent the most of the day there, visiting acquaintances and driving with them about the garden—the whole region is a garden, excepting the scene of the "Maungatapu Murders," of thirty years ago. That is a wild place—wild and lonely; an ideal place for a murder. It is at the base of a vast, rugged, densely timbered mountain. In the deep twilight of that forest solitude four desperate rascals—Burgess, Sullivan, Levy, and Kelley—ambushed themselves beside the mountain-trail to murder and rob four travelers—Kempthorne, Mathieu, Dudley, and De Pontius, the latter a New Yorker. A harmless old laboring man came wandering along, and as his presence was an embarrassment, they choked him, hid him, and then resumed their watch for the four. They had to wait a while, but eventually everything turned out as they desired.

That dark episode is the one large event in the history of Nelson. The fame of it traveled far. Burgess made a confession. It is a remarkable paper. For brevity, succinctness, and concentration, it is perhaps without its peer in the literature of murder. There are no waste words in it; there is no obtrusion of matter not pertinent to the occasion, nor any departure from the dispassionate tone proper to a formal business statement—for that is what it is: a business statement of a murder, by the chief engineer of it, or superintendent, or foreman, or whatever one may prefer to call him.

"We were getting impatient, when we saw four men and a pack-horse coming. I left my cover and had a look at the men, for Levy had told me that Mathieu was a small man and wore a large beard, and that it was a chestnut horse. I said, 'Here they come.' They were then a good distance away; I took the caps off my gun, and put fresh ones on. I said, 'You keep where you are, I'll put them up, and you give me your gun while you tie them.' It was arranged as I have described. The men came; they arrived within about fifteen yards when I stepped up and said, 'Stand! bail up!' That means all of them to get together. I made them fall back on the upper side of the road with their faces up the range, and Sullivan brought me his gun, and then tied their hands behind them. The horse was very quiet all the time, he did not move. When they were all tied, Sullivan took the horse up the hill, and put him in the bush; he cut the rope and let the swags'—[A "swag" is a kit, a pack, small baggage.]—fall on the ground, and then came to me. We then marched the men down the incline to the creek; the water at this time barely running. Up this creek we took the men; we went, I daresay, five or six hundred yards up it, which took us nearly half-an-hour to accomplish. Then we turned to the right up the range; we went, I daresay, one hundred and fifty yards from the creek, and there we sat down with the men. I said to Sullivan, 'Put down your gun and search these men,' which he did. I asked them their several names; they told me. I asked them if they were expected at Nelson. They said, 'No.' If such their lives would have been spared. In money we took L60 odd. I said, 'Is this all you have? You had better tell me.' Sullivan said, 'Here is a bag of gold.' I said, 'What's on that pack-horse? Is there any gold?' when Kempthorne said, 'Yes, my gold is in the portmanteau, and I trust you will not take it all.' 'Well,' I said, 'we must take you away one at a time, because the range is steep just here, and then we will let you go.' They said, 'All right,' most cheerfully. We tied their feet, and took Dudley with us; we went about

sixty yards with him. This was through a scrub. It was arranged the night previously that it would be best to choke them, in case the report of the arms might be heard from the road, and if they were missed they never would be found. So we tied a handkerchief over his eyes, when Sullivan took the sash off his waist, put it round his neck, and so strangled him. Sullivan, after I had killed the old laboring man, found fault with the way he was choked. He said, 'The next we do I'll show you my way.' I said, 'I have never done such a thing before. I have shot a man, but never choked one.' We returned to the others, when Kempthorne said, 'What noise was that?' I said it was caused by breaking through the scrub. This was taking too much time, so it was agreed to shoot them. With that I said, 'We'll take you no further, but separate you, and then loose one of you, and he can relieve the others.' So with that, Sullivan took De Pontius to the left of where Kempthorne was sitting. I took Mathieu to the right. I tied a strap round his legs, and shot him with a revolver. He yelled, I ran from him with my gun in my hand, I sighted Kempthorne, who had risen to his feet. I presented the gun, and shot him behind the right ear; his life's blood welled from him, and he died instantaneously. Sullivan had shot. De Pontius in the meantime, and then came to me. I said, 'Look to Mathieu,' indicating the spot where he lay. He shortly returned and said, 'I had to "chiv" that fellow, he was not dead,' a cant word, meaning that he had to stab him. Returning to the road we passed where De Pontius lay and was dead. Sullivan said, 'This is the digger, the others were all storekeepers; this is the digger, let's cover him up, for should the others be found, they'll think he done it and sloped,' meaning he had gone. So with that we threw all the stones on him, and then left him. This bloody work took nearly an hour and a half from the time we stopped the men."

Anyone who reads that confession will think that the man who wrote it was destitute of emotions, destitute of feeling. That is partly true. As regarded others he was plainly without feeling—utterly cold and pitiless; but as regarded himself the case was different. While he cared nothing for the future of the murdered men, he cared a great deal for his own. It makes one's flesh creep to read the introduction to his confession. The judge on the bench characterized it as "scandalously blasphemous," and it certainly reads so, but Burgess meant no blasphemy. He was merely a brute, and whatever he said or wrote was sure to expose the fact. His redemption was a very real thing to him, and he was as jubilantly happy on the gallows as ever was Christian martyr at the stake. We dwellers in this world are strangely made, and mysteriously circumstanced. We have to suppose that the murdered men are lost, and that Burgess is saved; but we cannot suppress our natural regrets.

"Written in my dungeon drear this 7th of August, in the year of Grace, 1866. To God be ascribed all power and glory in subduing the rebellious spirit of a most guilty wretch, who has been brought, through the instrumentality of a faithful follower of Christ, to see his wretched and guilty state, inasmuch as hitherto he has led an awful and wretched life, and through the assurance of this faithful soldier of Christ, he has been led and also believes that Christ will yet receive and cleanse him from all his deep-dyed and bloody sins. I lie under the imputation which says, 'Come now and let us reason together, saith the Lord: though your sins be as scarlet, they shall be as white as snow; though they be red like crimson, they shall be as wool.' On this promise I rely."

We sailed in the afternoon late, spent a few hours at New Plymouth, then sailed again and reached Auckland the next day, November 20th, and remained in that fine city several days. Its situation is commanding, and the sea-view is superb. There are charming drives all about, and by courtesy of friends we had opportunity to enjoy them. From the grassy crater-summit of Mount Eden one's eye ranges over a grand sweep and variety of scenery—forests clothed in luxuriant foliage, rolling green fields, conflagrations of flowers, receding and dimming stretches of green plain, broken by lofty and symmetrical old craters—then the blue bays twinkling and sparkling away into the dreamy distances where the mountains loom spiritual in their veils of haze.

Following the Equator, Illustrated, v4

It is from Auckland that one goes to Rotorua, the region of the renowned hot lakes and geysers—one of the chief wonders of New Zealand; but I was not well enough to make the trip. The government has a sanatorium there, and everything is comfortable for the tourist and the invalid. The government's official physician is almost over-cautious in his estimates of the efficacy of the baths, when he is talking about rheumatism, gout, paralysis, and such things; but when he is talking about the effectiveness of the waters in eradicating the whisky-habit, he seems to have no reserves. The baths will cure the drinking-habit no matter how chronic it is—and cure it so effectually that even the desire to drink intoxicants will come no more. There should be a rush from Europe and America to that place; and when the victims of alcoholism find out what they can get by going there, the rush will begin.



The Thermal-springs District of New Zealand comprises an area of upwards of 600,000 acres, or close on 1,000 square miles. Rotorua is the favorite place. It is the center of a rich field of lake and mountain scenery; from Rotorua as a base the pleasure-seeker makes excursions. The crowd of sick people is great, and growing. Rotorua is the Carlsbad of Australasia.

It is from Auckland that the Kauri gum is shipped. For a long time now about 8,000 tons of it have been brought into the town per year. It is worth about \$300 per ton, unassorted; assorted, the finest grades are worth about \$1,000. It goes to America, chiefly. It is in lumps, and is hard and smooth, and looks like amber—the light-colored like new amber, and the dark brown like rich old amber. And it has the pleasant feel of amber, too. Some of the light-colored samples were a tolerably fair counterfeit of uncut South African diamonds, they were so perfectly smooth and polished and transparent. It is manufactured into varnish; a varnish which answers for copal varnish and is cheaper.

The gum is dug up out of the ground; it has been there for ages. It is the sap of the Kauri tree. Dr. Campbell of Auckland told me he sent a cargo of it to England fifty years ago, but nothing came of the venture. Nobody knew what to do with it; so it was sold at 15 a ton, to light fires with.

November 26—3 P.M., sailed. Vast and beautiful harbor. Land all about for hours. Tangariwa, the mountain that "has the same shape from every point of view." That is the common belief in Auckland. And so it has— from every point of view except thirteen. Perfect summer weather. Large school of whales in the distance. Nothing could be daintier than the puffs of vapor they spout up, when seen against the pink glory of the sinking sun, or against the dark mass of an island reposing in the deep blue shadow of a storm cloud . . . Great Barrier rock standing up out of the sea away to the left. Sometime ago a ship hit it full speed in a fog—20 miles out of her course—140 lives lost; the captain committed suicide without waiting a moment. He knew that, whether he was to blame or not, the company owning the vessel would discharge him and make a devotion—to—passengers' safety advertisement out of it, and his chance to make a livelihood would be permanently gone.

CHAPTER XXXIV.

Let us not be too particular. It is better to have old second-hand diamonds than none at all.

—Pudd'nhead Wilson's New Calendar.

November 27. To-day we reached Gisborne, and anchored in a big bay; there was a heavy sea on, so we remained on board.

We were a mile from shore; a little steam-tug put out from the land; she was an object of thrilling interest; she would climb to the summit of a billow, reel drunkenly there a moment, dim and gray in the driving storm of spindrift, then make a plunge like a diver and remain out of sight until one had given her up, then up she would dart again, on a steep slant toward the sky, shedding Niagaras of water from her forecastle—and this she kept up, all the way out to us. She brought twenty-five passengers in her stomach—men and women mainly a traveling dramatic company. In sight on deck were the crew, in sou'westers, yellow waterproof canvas suits, and boots to the thigh. The deck was never quiet for a moment, and seldom nearer level than a ladder, and noble were the seas which leapt aboard and went flooding aft. We rove a long line to the yard-arm, hung a most primitive basketchair to it and swung it out into the spacious air of heaven, and there it swayed, pendulum-fashion, waiting for its chance—then down it shot, skillfully aimed, and was grabbed by the two men on the forecastle.



A young fellow belonging to our crew was in the chair, to be a protection to the lady-comers. At once a couple of ladies appeared from below, took seats in his lap, we hoisted them into the sky, waited a moment till the roll of the ship brought them in overhead, then we lowered suddenly away, and seized the chair as it struck the deck. We took the twenty-five aboard, and delivered twenty-five into the tug—among them several aged ladies, and one blind one—and all without accident. It was a fine piece of work.

Ours is a nice ship, roomy, comfortable, well-ordered, and satisfactory. Now and then we step on a rat in a hotel, but we have had no rats on shipboard lately; unless, perhaps in the Flora; we had more serious things to think of there, and did not notice. I have noticed that it is only in ships and hotels which still employ the odious Chinese gong, that you find rats. The reason would seem to be, that as a rat cannot tell the time of day by a clock, he won't stay where he cannot find out when dinner is ready.

November 29. The doctor tells me of several old drunkards, one spiritless loafer, and several far-gone moral wrecks who have been reclaimed by the Salvation Army and have remained staunch people and hard workers these two years. Wherever one goes, these testimonials to the Army's efficiency are forthcoming . . . This morning we had one of those whizzing green Ballarat flies in the room, with his stunning buzz-saw noise—the swiftest creature in the world except the lightning-flash. It is a stupendous force that is stored up in that little body. If we had it in a ship in the same proportion, we could spin from Liverpool to New York in the space of an hour—the time it takes to eat luncheon. The New Zealand express train is called the Ballarat Fly . . . Bad teeth in the colonies. A citizen told me they don't have teeth filled, but pull them out and put in false ones, and that now and then one sees a young lady with a full set. She is fortunate. I wish I had been born with false teeth and a false liver and false carbuncles. I should get along better.

December 2. Monday. Left Napier in the Ballarat Fly the one that goes twice a week. From Napier to Hastings, twelve miles; time, fifty-five minutes—not so far short of thirteen miles an hour . . . A perfect summer day; cool breeze, brilliant sky, rich vegetation. Two or three times during the afternoon we saw wonderfully dense and beautiful forests, tumultuously piled skyward on the broken highlands—not the customary roof-like slant of a hillside, where the trees are all the same height. The noblest of these trees were of the Kauri breed, we were told the timber that is now furnishing the wood-paving for Europe, and is the best of all wood for that purpose. Sometimes these towering upheavals of forestry were festooned and garlanded with vine-cables, and sometimes the masses of undergrowth were cocooned in another sort of vine of a delicate cobwebby texture—they call it the "supplejack," I think. Tree ferns everywhere—a stem fifteen feet high, with a graceful chalice of fern-fronds sprouting from its top—a lovely forest ornament. And there was a ten-foot reed with a flowing suit of what looked like yellow hair hanging from its upper end. I do not know its name, but if there is such a thing as a scalp-plant, this is it. A romantic gorge, with a brook flowing in its bottom, approaching Palmerston North.

Waitukurau. Twenty minutes for luncheon. With me sat my wife and daughter, and my manager, Mr. Carlyle Smythe. I sat at the head of the table, and could see the right-hand wall; the others had their backs to it. On that wall, at a good distance away, were a couple of framed pictures. I could not see them clearly, but from the groupings of the figures I fancied that they represented the killing of Napoleon III's son by the Zulus in South Africa. I broke into the conversation, which was about poetry and cabbage and art, and said to my wife—

"Do you remember when the news came to Paris——"

"Of the killing of the Prince?"

(Those were the very words I had in my mind.) "Yes, but what Prince?"

"Napoleon. Lulu."

"What made you think of that?"

"I don't know."

There was no collusion. She had not seen the pictures, and they had not been mentioned. She ought to have thought of some recent news that came to Paris, for we were but seven months from there and had been living

Following the Equator, Illustrated, v4

there a couple of years when we started on this trip; but instead of that she thought of an incident of our brief sojourn in Paris of sixteen years before.

Here was a clear case of mental telegraphy; of mind-transference; of my mind telegraphing a thought into hers. How do I know? Because I telegraphed an error. For it turned out that the pictures did not represent the killing of Lulu at all, nor anything connected with Lulu. She had to get the error from my head—it existed nowhere else.

CHAPTER XXXV.

The Autocrat of Russia possesses more power than any other man in the earth; but he cannot stop a sneeze.

—Pudd'nhead Wilson's New Calendar.

WAUGANIUI, December 3. A pleasant trip, yesterday, per Ballarat Fly. Four hours. I do not know the distance, but it must have been well along toward fifty miles. The Fly could have spun it out to eight hours and not discommoded me; for where there is comfort, and no need for hurry, speed is of no value—at least to me; and nothing that goes on wheels can be more comfortable, more satisfactory, than the New Zealand trains. Outside of America there are no cars that are so rationally devised. When you add the constant presence of charming scenery and the nearly constant absence of dust—well, if one is not content then, he ought to get out and walk. That would change his spirit, perhaps? I think so. At the end of an hour you would find him waiting humbly beside the track, and glad to be taken aboard again.

Much horseback riding, in and around this town; many comely girls in cool and pretty summer gowns; much Salvation Army; lots of Maoris; the faces and bodies of some of the old ones very tastefully frescoed. Maori Council House over the river—large, strong, carpeted from end to end with matting, and decorated with elaborate wood carvings, artistically executed. The Maoris were very polite.

I was assured by a member of the House of Representatives that the native race is not decreasing, but actually increasing slightly. It is another evidence that they are a superior breed of savages. I do not call to mind any savage race that built such good houses, or such strong and ingenious and scientific fortresses, or gave so much attention to agriculture, or had military arts and devices which so nearly approached the white man's. These, taken together with their high abilities in boat-building, and their tastes and capacities in the ornamental arts modify their savagery to a semi-civilization—or at least to, a quarter-civilization.



It is a compliment to them that the British did not exterminate them, as they did the Australians and the Tasmanians, but were content with subduing them, and showed no desire to go further. And it is another compliment to them that the British did not take the whole of their choicest lands, but left them a considerable part, and then went further and protected them from the rapacities of landsharks—a protection which the New Zealand Government still extends to them. And it is still another compliment to the Maoris that the Government allows native representation—in both the legislature and the cabinet, and gives both sexes the vote. And in doing these things the Government also compliments itself; it has not been the custom of the world for conquerors to act in this large spirit toward the conquered.

The highest class white men who lived among the Maoris in the earliest time had a high opinion of them and a strong affection for them. Among the whites of this sort was the author of "Old New Zealand;" and Dr. Campbell of Auckland was another. Dr. Campbell was a close friend of several chiefs, and has many pleasant things to say of their fidelity, their magnanimity, and their generosity. Also of their quaint notions about the white man's queer civilization, and their equally quaint comments upon it. One of them thought the missionary had got everything wrong end first and upside down. "Why, he wants us to stop worshiping and supplicating the evil gods, and go to worshiping and supplicating the Good One! There is no sense in that. A good god is not going to do us any harm."

The Maoris had the tabu; and had it on a Polynesian scale of comprehensiveness and elaboration. Some of its features could have been importations from India and Judea. Neither the Maori nor the Hindoo of common degree could cook by a fire that a person of higher caste had used, nor could the high Maori or high Hindoo employ fire that had served a man of low grade; if a low-grade Maori or Hindoo drank from a vessel belonging to a high-grade man, the vessel was defiled, and had to be destroyed. There were other resemblances between Maori tabu and Hindoo caste-custom.



Yesterday a lunatic burst into my quarters and warned me that the Jesuits were going to "cook" (poison) me in my food, or kill me on the stage at night. He said a mysterious sign was visible upon my posters and meant my death. He said he saved Rev. Mr. Haweis's life by warning him that there were three men on his platform who would kill him if he took his eyes off them for a moment during his lecture. The same men were in my audience last night, but they saw that he was there. "Will they be there again to-night?" He hesitated; then said no, he thought they would rather take a rest and chance the poison. This lunatic has no delicacy. But he was not uninteresting. He told me a lot of things. He said he had "saved so many lecturers in twenty years, that they put him in the asylum." I think he has less refinement than any lunatic I have met.

December 8. A couple of curious war-monuments here at Wanganui. One is in honor of white men "who fell in defence of law and order against fanaticism and barbarism." Fanaticism. We Americans are English in blood, English in speech, English in religion, English in the essentials of our governmental system, English in the essentials of our civilization; and so, let us hope, for the honor of the blend, for the honor of the blood, for the honor of the race, that that word got there through lack of heedfulness, and will not be suffered to remain. If you carve it at Thermopylae, or where Winkelried died, or upon Bunker Hill monument, and read it again "who fell in defence of law and order against fanaticism" you will perceive what the word means, and how mischosen it is. Patriotism is Patriotism. Calling it Fanaticism cannot degrade it; nothing can degrade it. Even though it be a political mistake, and a thousand times a political mistake, that does not affect it; it is honorable always honorable, always noble—and privileged to hold its head up and look the nations in the face. It is right to praise these brave white men who fell in the Maori war—they deserve it; but the presence of that word detracts from the dignity of their cause and their deeds, and makes them appear to have spilt their blood in a conflict with ignoble men, men not worthy of that costly sacrifice. But the men were worthy. It was no shame to fight them. They

fought for their homes, they fought for their country; they bravely fought and bravely fell; and it would take nothing from the honor of the brave Englishmen who lie under the monument, but add to it, to say that they died in defense of English laws and English homes against men worthy of the sacrifice—the Maori patriots.

The other monument cannot be rectified. Except with dynamite. It is a mistake all through, and a strangely thoughtless one. It is a monument erected by white men to Maoris who fell fighting with the whites and against their own people, in the Maori war. "Sacred to the memory of the brave men who fell on the 14th of May, 1864," etc. On one side are the names of about twenty Maoris. It is not a fancy of mine; the monument exists. I saw it. It is an object-lesson to the rising generation. It invites to treachery, disloyalty, unpatriotism. Its lesson, in frank terms is, "Desert your flag, slay your people, burn their homes, shame your nationality—we honor such."

December 9. Wellington. Ten hours from Wanganui by the Fly. December 12. It is a fine city and nobly situated. A busy place, and full of life and movement. Have spent the three days partly in walking about, partly in enjoying social privileges, and largely in idling around the magnificent garden at Hutt, a little distance away, around the shore. I suppose we shall not see such another one soon.

We are packing to-night for the return-voyage to Australia. Our stay in New Zealand has been too brief; still, we are not unthankful for the glimpse which we have had of it.

The sturdy Maoris made the settlement of the country by the whites rather difficult. Not at first—but later. At first they welcomed the whites, and were eager to trade with them—particularly for muskets; for their pastime was internecine war, and they greatly preferred the white man's weapons to their own. War was their pastime—I use the word advisedly. They often met and slaughtered each other just for a lark, and when there was no quarrel. The author of "Old New Zealand" mentions a case where a victorious army could have followed up its advantage and exterminated the opposing army, but declined to do it; explaining naively that "if we did that, there couldn't be any more fighting." In another battle one army sent word that it was out of ammunition, and would be obliged to stop unless the opposing army would send some. It was sent, and the fight went on.

In the early days things went well enough. The natives sold land without clearly understanding the terms of exchange, and the whites bought it without being much disturbed about the native's confusion of mind. But by and by the Maori began to comprehend that he was being wronged; then there was trouble, for he was not the man to swallow a wrong and go aside and cry about it. He had the Tasmanian's spirit and endurance, and a notable share of military science besides; and so he rose against the oppressor, did this gallant "fanatic," and started a war that was not brought to a definite end until more than a generation had sped.

CHAPTER XXXVI.

There are several good protections against temptations, but the surest is cowardice.

—Pudd'nhead Wilson's New Calendar.

Names are not always what they seem. The common Welsh name Bzjxllwep is pronounced Jackson.

—Pudd'nhead Wilson's New Calendar.

Friday, December 13. Sailed, at 3 p.m., in the 'Mararoa'. Summer seas and a good ship—life has nothing better.

Monday. Three days of paradise. Warm and sunny and smooth; the sea a luminous Mediterranean blue One lolls in a long chair all day under deck—awnings, and reads and smokes, in measureless content. One does not read prose at such a time, but poetry. I have been reading the poems of Mrs. Julia A. Moore, again, and I find in them the same grace and melody that attracted me when they were first published, twenty years ago, and have held me in happy bonds ever since.

"The Sentimental Song Book" has long been out of print, and has been forgotten by the world in general, but not by me. I carry it with me always—it and Goldsmith's deathless story.

Indeed, it has the same deep charm for me that the Vicar of Wakefield has, and I find in it the same subtle touch—the touch that makes an intentionally humorous episode pathetic and an intentionally pathetic one funny. In her time Mrs. Moore was called "the Sweet Singer of Michigan," and was best known by that name. I have read her book through twice today, with the purpose of determining which of her pieces has most merit, and I am persuaded that for wide grasp and sustained power, "William Upson" may claim first place

WILLIAM UPSON.

Air—"The Major's Only Son."
Come all good people far and near,
Oh, come and see what you can hear,
It's of a young man true and brave,
That is now sleeping in his grave.

Now, William Upson was his name
If it's not that, it's all the same
He did enlist in a cruel strife,
And it caused him to lose his life.

He was Perry Upson's eldest son,
His father loved his noble son,
This son was nineteen years of age
When first in the rebellion he engaged.

His father said that he might go,
But his dear mother she said no,

"Oh! stay at home, dear Billy," she said,
But she could not turn his head.

He went to Nashville, in Tennessee,
There his kind friends he could not see;
He died among strangers, so far away,
They did not know where his body lay.

He was taken sick and lived four weeks,
And Oh! how his parents weep,
But now they must in sorrow mourn,
For Billy has gone to his heavenly home.

Oh! if his mother could have seen her son,
For she loved him, her darling son;
If she could heard his dying prayer,
It would ease her heart till she met him there

How it would relieve his mother's heart
To see her son from this world depart,
And hear his noble words of love,
As he left this world for that above.

Now it will relieve his mother's heart,
For her son is laid in our graveyard;
For now she knows that his grave is near,
She will not shed so many tears.

Although she knows not that it was her son,
For his coffin could not be opened
It might be someone in his place,
For she could not see his noble face.

December, 17. Reached Sydney.

December, 19. In the train. Fellow of 30 with four valises; a slim creature, with teeth which made his mouth look like a neglected churchyard. He had solidified hair—solidified with pomatum; it was all one shell. He smoked the most extraordinary cigarettes—made of some kind of manure, apparently. These and his hair made him smell like the very nation. He had a low-cut vest on, which exposed a deal of frayed and broken and unclean shirtfront. Showy studs, of imitation gold—they had made black disks on the linen. Oversized sleeve buttons of imitation gold, the copper base showing through. Ponderous watch—chain of imitation gold. I judge that he couldn't tell the time by it, for he asked Smythe what time it was, once. He wore a coat which had been gay when it was young; 5-o'clock-tea-trousers of a light tint, and marvelously soiled; yellow mustache with a dashing upward whirl at the ends; foxy shoes, imitation patent leather. He was a novelty—an imitation dude. He would have been a real one if he could have afforded it. But he was satisfied with himself. You could see it in his expression, and in all his attitudes and movements. He was living in a dude dreamland where all his squalid shams were genuine, and himself a sincerity. It disarmed criticism, it mollified spite, to see him so enjoy his imitation languors, and arts, and airs, and his studied daintinesses of gesture and misbegotten refinements. It was plain to me that he was imagining himself the Prince of Wales, and was doing everything

Following the Equator, Illustrated, v4

the way he thought the Prince would do it. For bringing his four valises aboard and stowing them in the nettings, he gave his porter four cents, and lightly apologized for the smallness of the gratuity— just with the condescendingest little royal air in the world. He stretched himself out on the front seat and rested his pomatum-cake on the middle arm, and stuck his feet out of the window, and began to pose as the Prince and work his dreams and languors for exhibition; and he would indolently watch the blue films curling up from his cigarette, and inhale the stench, and look so grateful; and would flip the ash away with the daintiest gesture, unintentionally displaying his brass ring in the most intentional way; why, it was as good as being in Marlborough House itself to see him do it so like.

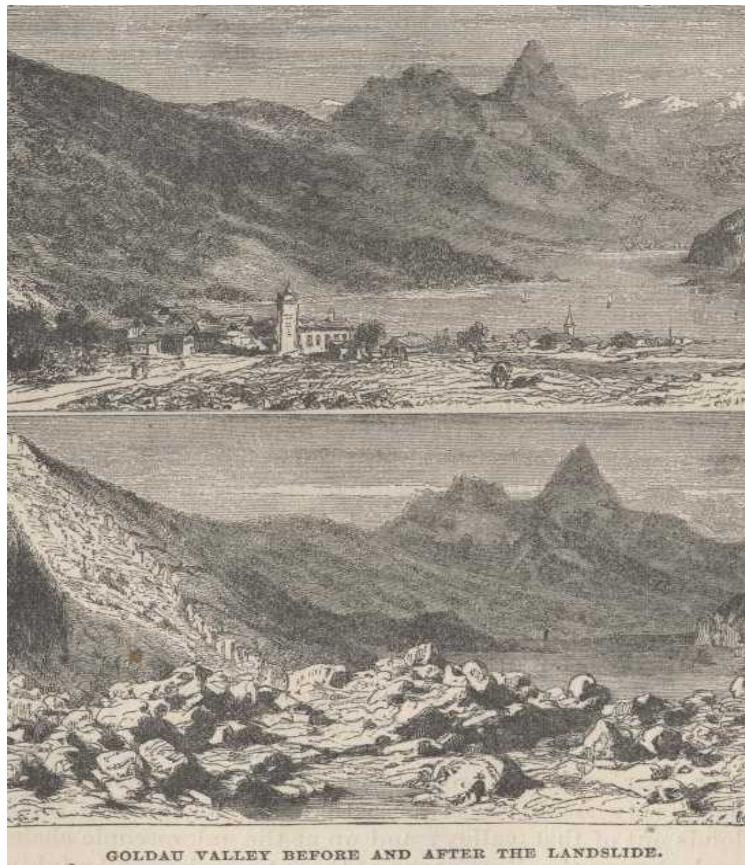

There was other scenery in the trip. That of the Hawksbury river, in the National Park region, fine—extraordinarily fine, with spacious views of stream and lake imposingly framed in woody hills; and every now and then the noblest groupings of mountains, and the most enchanting rearrangements of the water effects. Further along, green flats, thinly covered with gum forests, with here and there the huts and cabins of small farmers engaged in raising children. Still further along, arid stretches, lifeless and melancholy. Then Newcastle, a rushing town, capital of the rich

Following the Equator, Illustrated, v4

coal regions. Approaching Scone, wide farming and grazing levels, with pretty frequent glimpses of a troublesome plant—a particularly devilish little prickly pear, daily damned in the orisons of the agriculturist; imported by a lady of sentiment, and contributed gratis to the colony. Blazing hot, all day.

December 20. Back to Sydney. Blazing hot again. From the newspaper, and from the map, I have made a collection of curious names of Australasian towns, with the idea of making a poem out of them:

Tumut
Takee
Murriwillumba
Bowral
Ballarat
Mullengudgerie
Murrurundi
Wagga–Wagga
Wyalong
Murrumbidgee
Goomeroo
Wolloway
Wangary
Wanilla
Worror
Koppio
Yankalilla
Yaranyacka
Yackamoorundie
Kaiwaka
Coomooroo
Tauranga
Geelong
Tongariro
Kaikoura
Wakatipu
Ohipara
Waitpinga
Goelwa
Munno Para
Nangkita
Myponga
Kapunda
Kooringa
Penola
Nangwarry
Kongorong
Comaum
Koolywurtie
Killanoola
Naracoorte
Muloowurtie

Following the Equator, Illustrated, v4

Binnun
Wallaroo
Wirrega
Mundoora
Hauraki
Rangiriri
Teawamute
Taranaki
Toowoomba
Goondiwindi
Jerrilderie
Whangaroa
Wollongong
Woolloomooloo
Bombola
Coolgardie
Bendigo
Coonamble
Cootamundra
Woolgoolga
Mittagong
Jamberoo
Kondoparinga
Kuitpo
Tungkillo
Oukaparinga
Talunga
Yatala
Parawirra
Moorooroo
Whangarei
Woolundunga
Booleeroo
Pernatty
Parramatta
Taroom
Narrandera
Deniliquin
Kawakawa.

It may be best to build the poem now, and make the weather help

A SWELTERING DAY IN AUSTRALIA.

(To be read soft and low, with the lights turned down.)

The Bombola faints in the hot Bowral tree,
Where fierce Mullengudgery's smothering fires
Far from the breezes of Coolgardie
Burn ghastly and blue as the day expires;

And Murriwillumba complaineth in song
For the garlanded bowers of Woolloomooloo,
And the Ballarat Fly and the lone Wollongong
They dream of the gardens of Jamberoo;

The wallabi sighs for the Murrubidgee,
For the velvety sod of the Munno Parah,
Where the waters of healing from Muloowurtie
Flow dim in the gloaming by Yaranyackah;

The Koppio sorrows for lost Wolloway,
And sigheth in secret for Murrurundi,
The Whangeroo wombat lamenteth the day
That made him an exile from Jerrilderie;

The Teawamute Tumut from Wirrega's glade,
The Nangkita swallow, the Wallaroo swan,
They long for the peace of the Timaru shade
And thy balmy soft airs, O sweet Mittagong!

The Kooringa buffalo pants in the sun,
The Kondoparinga lies gaping for breath,
The Kongorong Camaum to the shadow has won,
But the Goomeroo sinks in the slumber of death;

In the weltering hell of the Moorooroo plain
The Yatala Wangary withers and dies,
And the Worrow Wanilla, demented with pain,
To the Woolgoolga woodlands despairingly flies;

Sweet Nangwarry's desolate, Coonamble wails,
And Tungkillo Kuito in sables is drest,
For the Whangerei winds fall asleep in the sails
And the Booleroo life-breeze is dead in the west.

Mypongo, Kapunda, O slumber no more
Yankalilla, Parawirra, be warned
There's death in the air!
Killanoola, wherefore

Following the Equator, Illustrated, v4

Shall the prayer of Penola be scorned?

Cootamundra, and Takee, and Wakatipu,
Toowoomba, Kaikoura are lost
From Onkaparinga to far Oamaru
All burn in this hell's holocaust!

Paramatta and Binnun are gone to their rest
In the vale of Tapanni Taroom,
Kawakawa, Deniliquin—all that was best
In the earth are but graves and a tomb!

Narrandera mourns, Cameron answers not
When the roll of the scathless we cry
Tongariro, Goondiwindi, Woolundunga, the spot
Is mute and forlorn where ye lie.

Those are good words for poetry. Among the best I have ever seen. There are 81 in the list. I did not need them all, but I have knocked down 66 of them; which is a good bag, it seems to me, for a person not in the business. Perhaps a poet laureate could do better, but a poet laureate gets wages, and that is different. When I write poetry I do not get any wages; often I lose money by it. The best word in that list, and the most musical and gurgly, is Woolloomooloo. It is a place near Sydney, and is a favorite pleasure-resort. It has eight O's in it.



CHAPTER XXXVII.

To succeed in the other trades, capacity must be shown; in the law, concealment of it will do.

—Pudd'nhead Wilson's New Calendar.

MONDAY,—December 23, 1895. Sailed from Sydney for Ceylon in the P. & O. steamer 'Oceana'. A Lascar crew mans this ship—the first I have seen. White cotton petticoat and pants; barefoot; red shawl for belt; straw cap, brimless, on head, with red scarf wound around it; complexion a rich dark brown; short straight black hair; whiskers fine and silky; lustrous and intensely black. Mild, good faces; willing and obedient people; capable, too; but are said to go into hopeless panics when there is danger. They are from Bombay and the coast thereabouts. Left some of the trunks in Sydney, to be shipped to South Africa by a vessel advertised to sail three months hence. The proverb says: "Separate not yourself from your baggage."

This 'Oceana' is a stately big ship, luxuriously appointed. She has spacious promenade decks. Large rooms; a surpassingly comfortable ship. The officers' library is well selected; a ship's library is not usually that . . . For meals, the bugle call, man-of-war fashion; a pleasant change from the terrible gong . . . Three big cats—very friendly loafers; they wander all over the ship; the white one follows the chief steward around like a dog. There is also a basket of kittens. One of these cats goes ashore, in port, in England, Australia, and India, to see how his various families are getting along, and is seen no more till the ship is ready to sail. No one knows how he finds out the sailing date, but no doubt he comes down to the dock every day and takes a look, and when he sees baggage and passengers flocking in, recognizes that it is time to get aboard. This is what the sailors believe. . . .

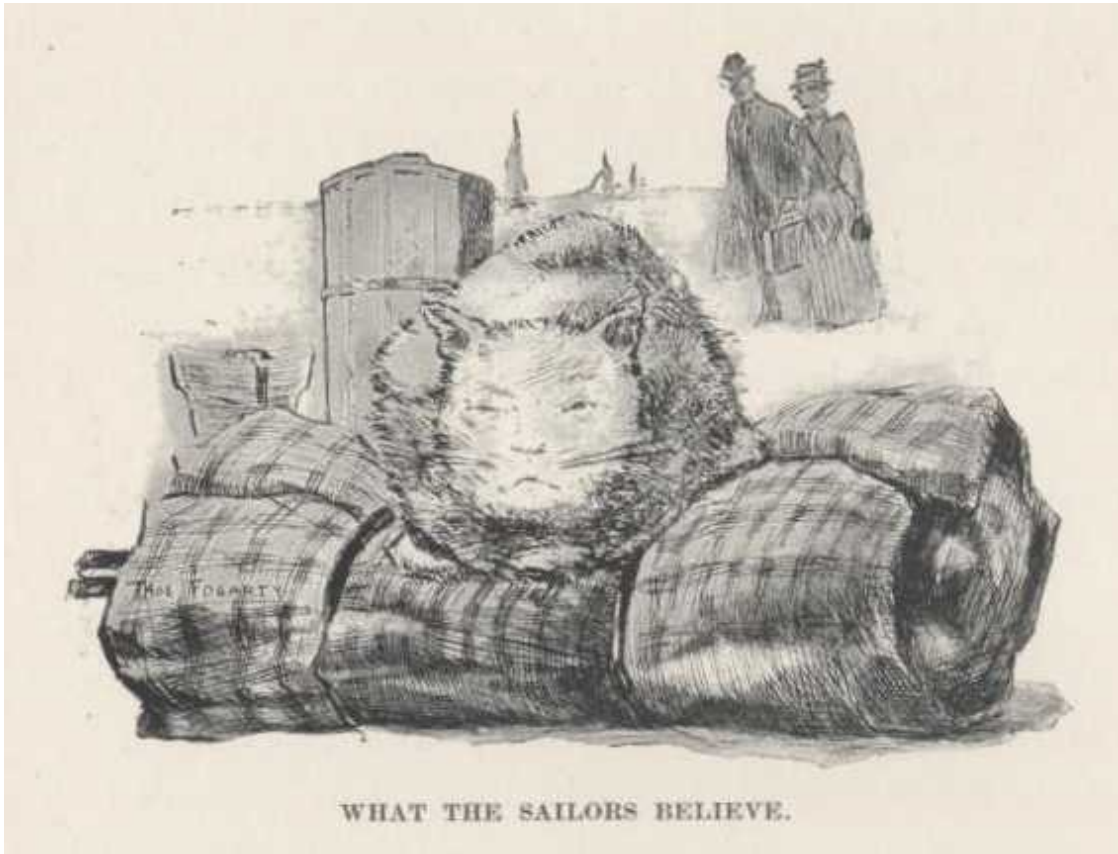

The Chief Engineer has been in the China and India trade thirty three years, and has had but three Christmases at home in that time . . . Conversational items at dinner, "Mocha! sold all over the world! It is not true. In fact, very few foreigners except the Emperor of Russia have ever seen a grain of it, or ever will, while they live." Another man said: "There is no sale in Australia for Australian wine. But it goes to France and comes back with a French label on it, and then they buy it." I have heard that the most of the French-labeled claret in New York is made in California. And I remember what Professor S. told me once about Veuve Cliquot—if that was the wine, and I think it was. He was the guest of a great wine merchant whose town was quite near that vineyard, and this merchant asked him if very much V. C. was drunk in America.

"Oh, yes," said S., "a great abundance of it."

"Is it easy to be had?"

"Oh, yes—easy as water. All first and second-class hotels have it."

"What do you pay for it?"

"It depends on the style of the hotel—from fifteen to twenty-five francs a bottle."

"Oh, fortunate country! Why, it's worth 100 francs right here on the ground."

"No!"

"Yes!"

"Do you mean that we are drinking a bogus Veuve–Cliquot over there?"

"Yes—and there was never a bottle of the genuine in America since Columbus's time. That wine all comes from a little bit of a patch of ground which isn't big enough to raise many bottles; and all of it that is produced goes every year to one person—the Emperor of Russia. He takes the whole crop in advance, be it big or little."

January 4, 1898. Christmas in Melbourne, New Year's Day in Adelaide, and saw most of the friends again in both places . . . Lying here at anchor all day—Albany (King George's Sound), Western Australia. It is a perfectly landlocked harbor, or roadstead—spacious to look at, but not deep water. Desolate-looking rocks and scarred hills. Plenty of ships arriving now, rushing to the new gold-fields. The papers are full of wonderful tales of the sort always to be heard in connection with new gold diggings. A sample: a youth staked out a claim and tried to sell half for L5; no takers; he stuck to it fourteen days, starving, then struck it rich and sold out for L10,000. . . About sunset, strong breeze blowing, got up the anchor. We were in a small deep puddle, with a narrow channel leading out of it, minutely buoyed, to the sea.

I stayed on deck to see how we were going to manage it with such a big ship and such a strong wind. On the bridge our giant captain, in uniform; at his side a little pilot in elaborately gold-laced uniform; on the forecastle a white mate and quartermaster or two, and a brilliant crowd of lascars standing by for business. Our stern was pointing straight at the head of the channel; so we must turn entirely around in the puddle—and the wind blowing as described. It was done, and beautifully. It was done by help of a jib. We stirred up much mud, but did not touch the bottom. We turned right around in our tracks—a seeming impossibility. We had several casts of quarter-less 5, and one cast of half 4—27 feet; we were drawing 26 astern. By the time we were entirely around and pointed, the first buoy was not more than a hundred yards in front of us. It was a fine piece of work, and I was the only passenger that saw it. However, the others got their dinner; the P. & O. Company got mine . . . More cats developed. Smythe says it is a British law that they must be carried; and he instanced a case of a ship not allowed to sail till she sent for a couple. The bill came, too: "Debtor, to 2 cats, 20 shillings." . . . News comes that within this week Siam has acknowledged herself to be, in effect, a French province. It seems plain that all savage and semi-civilized countries are going to be grabbed . . . A vulture on board; bald, red, queer-shaped head, featherless red places here and there on his body, intense great black eyes set in featherless rims of inflamed flesh; dissipated look; a businesslike style, a selfish, conscienceless, murderous aspect—the very look of a professional assassin, and yet a bird which does no murder. What was the use of getting him up in that tragic style for so innocent a trade as his? For this one isn't the sort that wars upon the living, his diet is offal—and the more out of date it is the better he likes it. Nature should give him a suit of rusty black; then he would be all right, for he would look like an undertaker and would harmonize with his business; whereas the way he is now he is horribly out of true.

January 5. At 9 this morning we passed Cape Leeuwin (lioness) and ceased from our long due-west course along the southern shore of Australia. Turning this extreme southwestern corner, we now take a long straight slant nearly N. W., without a break, for Ceylon. As we speed northward it will grow hotter very fast—but it isn't chilly, now. . . . The vulture is from the public menagerie at Adelaide—a great and interesting collection. It was there that we saw the baby tiger solemnly spreading its mouth and trying to roar like its majestic mother. It

swaggered, scowling, back and forth on its short legs just as it had seen her do on her long ones, and now and then snarling viciously, exposing its teeth, with a threatening lift of its upper lip and bristling moustache; and when it thought it was impressing the visitors, it would spread its mouth wide and do that screechy cry which it meant for a roar, but which did not deceive. It took itself quite seriously, and was lovably comical. And there was a hyena—an ugly creature; as ugly as the tiger—kitty was pretty. It repeatedly arched its back and delivered itself of such a human cry; a startling resemblance; a cry which was just that of a grown person badly hurt. In the dark one would assuredly go to its assistance—and be disappointed Many friends of Australasian Federation on board. They feel sure that the good day is not far off, now. But there seems to be a party that would go further— have Australasia cut loose from the British Empire and set up housekeeping on her own hook. It seems an unwise idea. They point to the United States, but it seems to me that the cases lack a good deal of being alike. Australasia governs herself wholly—there is no interference; and her commerce and manufactures are not oppressed in any way. If our case had been the same we should not have gone out when we did.

January 13. Unspeakably hot. The equator is arriving again. We are within eight degrees of it. Ceylon present. Dear me, it is beautiful! And most sumptuously tropical, as to character of foliage and opulence of it. "What though the spicy breezes blow soft o'er Ceylon's isle"—an eloquent line, an incomparable line; it says little, but conveys whole libraries of sentiment, and Oriental charm and mystery, and tropic deliciousness—a line that quivers and tingles with a thousand unexpressed and inexpressible things, things that haunt one and find no articulate voice Colombo, the capital. An Oriental town, most manifestly; and fascinating.

In this palatial ship the passengers dress for dinner. The ladies' toilettes make a fine display of color, and this is in keeping with the elegance of the vessel's furnishings and the flooding brilliancies of the electric light. On the stormy Atlantic one never sees a man in evening dress, except at the rarest intervals; and then there is only one, not two; and he shows up but once on the voyage—the night before the ship makes port—the night when they have the "concert" and do the amateur wailings and recitations. He is the tenor, as a rule There has been a deal of cricket—playing on board; it seems a queer game for a ship, but they enclose the promenade deck with nettings and keep the ball from flying overboard, and the sport goes very well, and is properly violent and exciting We must part from this vessel here.

January 14. Hotel Bristol. Servant Brompy. Alert, gentle, smiling, winning young brown creature as ever was. Beautiful shining black hair combed back like a woman's, and knotted at the back of his head— tortoise-shell comb in it, sign that he is a Singhalese; slender, shapely form; jacket; under it is a beltless and flowing white cotton gown—from neck straight to heel; he and his outfit quite unmasculine. It was an embarrassment to undress before him.



We drove to the market, using the Japanese jinriksha—our first acquaintanceship with it. It is a light cart, with a native to draw it. He makes good speed for half-an-hour, but it is hard work for him; he is too slight for it. After the half-hour there is no more pleasure for you; your attention is all on the man, just as it would be on a tired horse, and necessarily your sympathy is there too. There's a plenty of these 'rickshas, and the tariff is incredibly cheap.

I was in Cairo years ago. That was Oriental, but there was a lack. When you are in Florida or New Orleans you are in the South—that is granted; but you are not in the South; you are in a modified South, a tempered South. Cairo was a tempered Orient—an Orient with an indefinite something wanting. That feeling was not present in Ceylon. Ceylon was Oriental in the last measure of completeness—utterly Oriental; also utterly tropical; and indeed to one's unreasoning spiritual sense the two things belong together. All the requisites were present. The costumes were right; the black and brown exposures, unconscious of immodesty, were right; the juggler was there, with his basket, his snakes, his mongoose, and his arrangements for growing a tree from seed to foliage and ripe fruitage before one's eyes; in sight were plants and flowers familiar to one on books but in no other way celebrated, desirable, strange, but in production restricted to the hot belt of the equator; and out a little way in the country were the proper deadly snakes, and fierce beasts of prey, and the wild elephant and the monkey. And there was that swoon in the air which one associates with the tropics, and that smother of heat, heavy with odors of unknown flowers, and that sudden invasion of purple gloom fissured with lightnings,—then the tumult of crashing thunder and the downpour and presently

all sunny and smiling again; all these things were there; the conditions were complete, nothing was lacking. And away off in the deeps of the jungle and in the remotenesses of the mountains were the ruined cities and mouldering temples, mysterious relics of the pomps of a forgotten time and a vanished race—and this was as it should be, also, for nothing is quite satisfyingly Oriental that lacks the somber and impressive qualities of mystery and antiquity.

The drive through the town and out to the Galle Face by the seashore, what a dream it was of tropical splendors of bloom and blossom, and Oriental conflagrations of costume! The walking groups of men, women, boys, girls, babies—each individual was a flame, each group a house afire for color. And such stunning colors, such intensely vivid colors, such rich and exquisite minglings and fusings of rainbows and lightnings! And all harmonious, all in perfect taste; never a discordant note; never a color on any person swearing at another color on him or failing to harmonize faultlessly with the colors of any group the wearer might join. The stuffs were silk—thin, soft, delicate, clinging; and, as a rule, each piece a solid color: a splendid green, a splendid blue, a splendid yellow, a splendid purple, a splendid ruby, deep, and rich with smouldering fires they swept continuously by in crowds and legions and multitudes, glowing, flashing, burning, radiant; and every five seconds came a burst of blinding red that made a body catch his breath, and filled his heart with joy. And then, the unimaginable grace of those costumes! Sometimes a woman's whole dress was but a scarf wound about her person and her head, sometimes a man's was but a turban and a careless rag or two—in both cases generous areas of polished dark skin showing—but always the arrangement compelled the homage of the eye and made the heart sing for gladness.

I can see it to this day, that radiant panorama, that wilderness of rich color, that incomparable dissolving—view of harmonious tints, and lithe half—covered forms, and beautiful brown faces, and gracious and graceful gestures and attitudes and movements, free, unstudied, barren of stiffness and restraint, and—

Just then, into this dream of fairyland and paradise a grating dissonance was injected.

Out of a missionary school came marching, two and two, sixteen prim and pious little Christian black girls, Europeanly clothed—dressed, to the last detail, as they would have been dressed on a summer Sunday in an English or American village. Those clothes—oh, they were unspeakably ugly! Ugly, barbarous, destitute of taste, destitute of grace, repulsive as a shroud. I looked at my womenfolk's clothes—just full—grown duplicates of the outrages disguising those poor little abused creatures—and was ashamed to be seen in the street with them. Then I looked at my own clothes, and was ashamed to be seen in the street with myself.

MSC-023 / MSC-024

May 1971

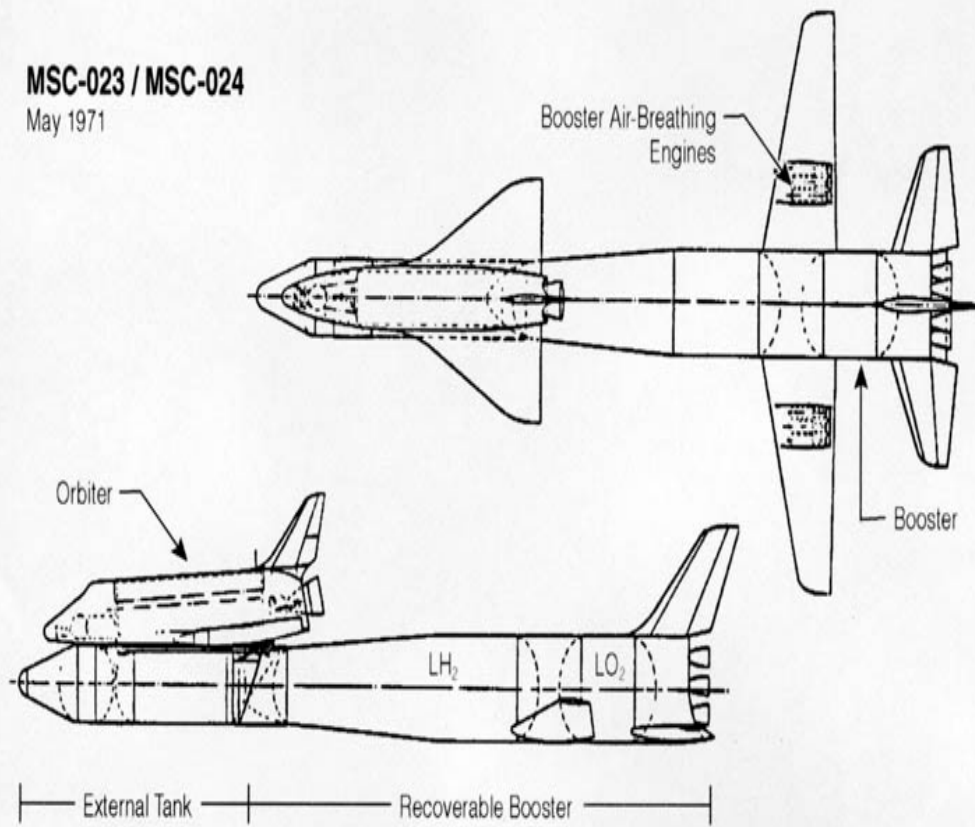

MSC-037

June 1971

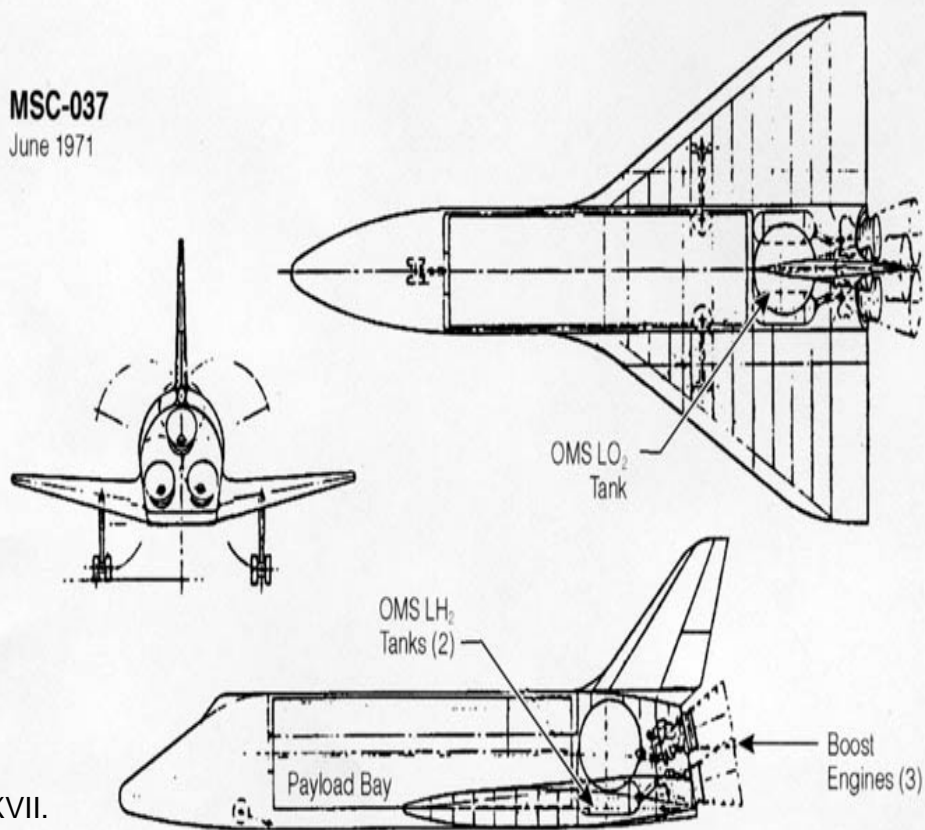

However, we must put up with our clothes as they are—they have their reason for existing. They are on us to expose us—to advertise what we wear them to conceal. They are a sign; a sign of insincerity; a sign of suppressed vanity; a pretense that we despise gorgeous colors and the graces of harmony and form; and we put them on to propagate that lie and back it up. But we do not deceive our neighbor; and when we step into Ceylon we realize that we have not even deceived ourselves. We do love brilliant colors and graceful costumes; and at home we will turn out in a storm to see them when the procession goes by—and envy the wearers. We go to the theater to look at them and grieve that we can't be clothed like that. We go to the King's ball, when we get a chance, and are glad of a sight of the splendid uniforms and the glittering orders. When we are granted permission to attend an imperial drawing-room we shut ourselves up in private and parade around in the theatrical court-dress by the hour, and admire ourselves in the glass, and are utterly happy; and every member of every governor's staff in democratic America does the same with his grand new uniform—and if he is not watched he will get himself photographed in it, too. When I see the Lord Mayor's footman I am dissatisfied with my lot. Yes, our clothes are a lie, and have been nothing short of that these hundred years. They are insincere, they are the ugly and appropriate outward exposure of an inward sham and a moral decay.

The last little brown boy I chanced to notice in the crowds and swarms of Colombo had nothing on but a twine string around his waist, but in my memory the frank honesty of his costume still stands out in pleasant contrast with the odious flummery in which the little Sunday-school dowdies were masquerading.



CHAPTER XXXVIII.

Prosperity is the best protector of principle.

—Pudd'nhead Wilson's New Calendar.

EVENING—11th. Sailed in the Rosetta. This is a poor old ship, and ought to be insured and sunk. As in the 'Oceana', just so here: everybody dresses for dinner; they make it a sort of pious duty. These fine and formal costumes are a rather conspicuous contrast to the poverty and shabbiness of the surroundings If you want a slice of a lime at four o'clock tea, you must sign an order on the bar. Limes cost 14 cents a barrel.

January 18th. We have been running up the Arabian Sea, latterly. Closing up on Bombay now, and due to arrive this evening.

January 20th. Bombay! A bewitching place, a bewildering place, an enchanting place—the Arabian Nights come again? It is a vast city; contains about a million inhabitants. Natives, they are, with a slight sprinkling of white people—not enough to have the slightest modifying effect upon the massed dark complexion of the public. It is winter here, yet the weather is the divine weather of June, and the foliage is the fresh and heavenly foliage of June. There is a rank of noble great shade trees across the way from the hotel, and under them sit groups of picturesque natives of both sexes; and the juggler in his turban is there with his snakes and his magic; and all day long the cabs and the multitudinous varieties of costumes flock by. It does not seem as if one could ever get tired of watching this moving show, this shining and shifting spectacle In the great bazaar the pack and jam of natives was marvelous, the sea of rich-colored turbans and draperies an inspiring sight, and the quaint and showy Indian architecture was just the right setting for it. Toward sunset another show; this is the drive around the sea-shore to Malabar Point, where Lord Sandhurst, the Governor of the Bombay Presidency, lives. Parsee palaces all along the first part of the drive; and past them all the world is driving; the private carriages of wealthy Englishmen and natives of rank are manned by a driver and three footmen in stunning oriental liveries—two of these turbaned statues standing up behind, as fine as monuments. Sometimes even the public carriages have this superabundant crew, slightly modified—one to drive, one to sit by and see it done, and one to stand up behind and yell—yell when there is anybody in the way, and for practice when there isn't. It all helps to keep up the liveliness and augment the general sense of swiftness and energy and confusion and pow—wow.

In the region of Scandal Point—felicitous name—where there are handy rocks to sit on and a noble view of the sea on the one hand, and on the other the passing and reprising whirl and tumult of gay carriages, are great groups of comfortably—off Parsee women—perfect flower-beds of brilliant color, a fascinating spectacle. Tramp, tramp, tramping along the road, in singles, couples, groups, and gangs, you have the working—man and the working—woman—but not clothed like ours. Usually the man is a nobly—built great athlete, with not a

Following the Equator, Illustrated, v4

rag on but his loin-handkerchief; his color a deep dark brown, his skin satin, his rounded muscles knobbing it as if it had eggs under it. Usually the woman is a slender and shapely creature, as erect as a lightning-rod, and she has but one thing on—a bright-colored piece of stuff which is wound about her head and her body down nearly half-way to her knees, and which clings like her own skin. Her legs and feet are bare, and so are her arms, except for her fanciful bunches of loose silver rings on her ankles and on her arms. She has jewelry bunched on the side of her nose also, and showy clusterrings on her toes. When she undresses for bed she takes off her jewelry, I suppose. If she took off anything more she would catch cold. As a rule she has a large shiny brass water jar of graceful shape on her head, and one of her naked arms curves up and the hand holds it there. She is so straight, so erect, and she steps with such style, and such easy grace and dignity; and her curved arm and her brazen jar are such a help to the picture indeed, our working-women cannot begin with her as a road-decoration.

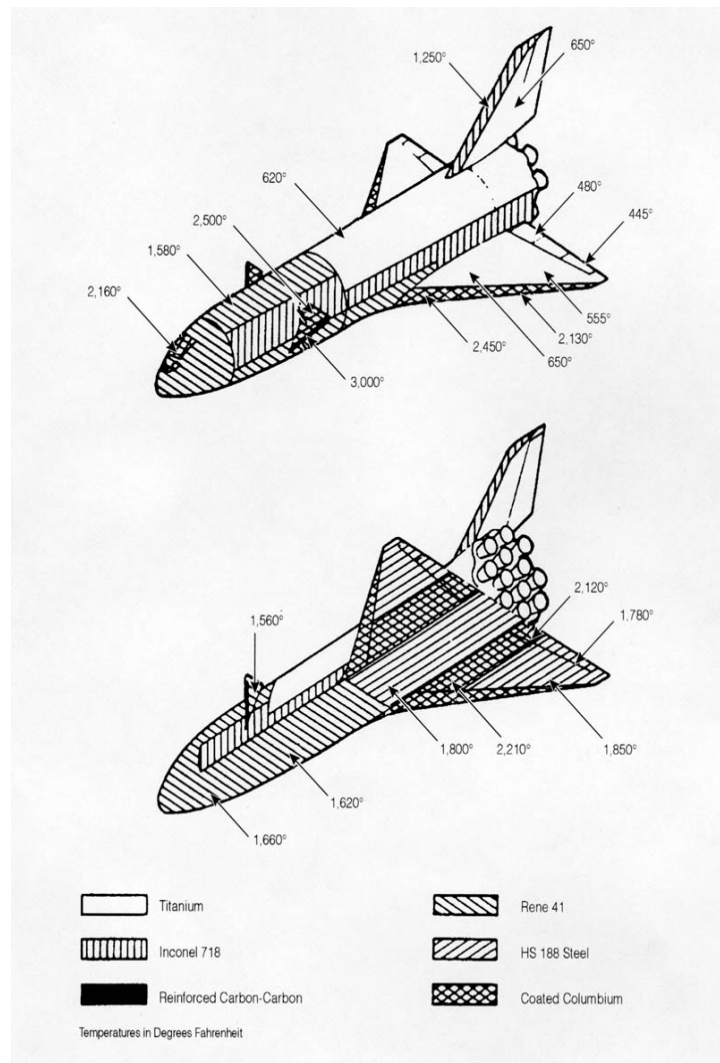

It is all color, bewitching color, enchanting color—everywhere all around—all the way around the curving great opaline bay clear to Government House, where the turbaned big native 'chuprassies' stand grouped in state at the door in their robes of fiery red, and do most properly and stunningly finish up the splendid show and make it theatrically complete. I wish I were a 'chuprassy'.

This is indeed India! the land of dreams and romance, of fabulous wealth and fabulous poverty, of splendor and rags, of palaces and hovels, of famine and pestilence, of genii and giants and Aladdin lamps, of tigers and elephants, the cobra and the jungle, the country of a hundred nations and a hundred tongues, of a thousand religions and two million gods, cradle of the human race, birthplace of human speech, mother of history, grandmother of legend, great-grandmother of tradition, whose yesterdays bear date with the mouldering antiquities of the rest of the nations—the one sole country under the sun that is endowed with an imperishable interest for alien prince and alien peasant, for lettered and ignorant, wise and fool, rich and poor, bond and free, the one land that all men desire to see, and having seen once, by even a glimpse, would not give that glimpse for the shows of all the rest of the globe combined. Even now, after the lapse of a year, the delirium of those days in Bombay has not left me, and I hope never will. It was all new, no detail of it hackneyed. And India did not wait for morning, it began at the hotel— straight away. The lobbies and halls were full of turbaned, and fez'd and embroidered, cap'd, and barefooted, and cotton-clad dark natives, some of them rushing about, others at rest squatting, or sitting on the ground; some of them chattering with energy, others still and dreamy; in the dining-room every man's own private native servant standing behind his chair, and dressed for a part in the Arabian Nights.

Our rooms were high up, on the front. A white man he was a burly German—went up with us, and brought three natives along to see to arranging things. About fourteen others followed in procession, with the hand-baggage; each carried an article—and only one; a bag, in some cases, in other cases less. One strong native carried my overcoat, another a parasol, another a box of cigars, another a novel, and the last man in the procession had no load but a fan. It was all done with earnestness and sincerity, there was not a smile in the procession from the head of it to the tail of it. Each man waited patiently, tranquilly, in no sort of hurry, till one of us found time to give him a copper, then he bent his head reverently, touched his forehead with his fingers, and went his way. They seemed a soft and gentle race, and there was something both winning and touching about their demeanor.



There was a vast glazed door which opened upon the balcony. It needed closing, or cleaning, or something, and a native got down on his knees and went to work at it. He seemed to be doing it well enough, but perhaps he wasn't, for the burly German put on a look that betrayed dissatisfaction, then without explaining what was wrong, gave the native a brisk cuff on the jaw and then told him where the defect was. It seemed such a shame to do that before us all. The native took it with meekness, saying nothing, and not showing in his face or manner any resentment. I had not seen the like of this for fifty years. It carried me back to my boyhood, and flashed upon me the forgotten fact that this was the usual way of explaining one's desires to a slave. I was able to remember that the method seemed right and natural to me in those days, I being born to it and unaware that elsewhere there were other methods; but I was also able to remember that those unresented cuffings made me sorry for the victim and ashamed for the punisher. My father was a refined and kindly gentleman, very grave, rather austere, of rigid probity, a sternly just and upright man, albeit he attended no church and never spoke of religious matters, and had no part nor lot in the pious joys of his Presbyterian family, nor ever seemed to suffer from this deprivation. He laid his hand upon me in punishment only twice in his life, and then not heavily; once for telling him a lie—which surprised me, and showed me how unsuspecting he was, for that was not my maiden effort. He punished me those two times only, and never any other member of the family at all; yet every now and then he cuffed our harmless slave boy, Lewis, for trifling little blunders and awkwardnesses. My father had passed his life among the slaves from his cradle up, and his cuffings proceeded from the custom of the time, not from his nature. When I was ten years old I saw a man fling a lump of iron-ore at a slaveman in anger, for merely doing something awkwardly—as if that were a crime. It bounded from the man's skull, and the man fell and never spoke again. He was dead in an hour. I knew the man had a right to kill his slave if he wanted to, and yet it seemed a pitiful thing and somehow wrong, though why wrong I was not deep enough to explain if I had been asked to do it. Nobody in the village approved of that murder, but of course no one said much about it.

It is curious—the space-annihilating power of thought. For just one second, all that goes to make the me in me was in a Missourian village, on the other side of the globe, vividly seeing again these forgotten pictures of fifty years ago, and wholly unconscious of all things but just those; and in the next second I was back in Bombay, and that kneeling native's smitten cheek was not done tingling yet! Back to boyhood—fifty years; back to age again, another fifty; and a flight equal to the circumference of the globe—all in two seconds by the watch!

Some natives—I don't remember how many—went into my bedroom, now, and put things to rights and arranged the mosquito-bar, and I went to bed to nurse my cough. It was about nine in the evening. What a state of things! For three hours the yelling and shouting of natives in the hall continued, along with the velvety patter of their swift bare feet—what a racket it was! They were yelling orders and messages down three flights. Why, in the matter of noise it amounted to a riot, an insurrection, a revolution. And then there were other

noises mixed up with these and at intervals tremendously accenting them—roofs falling in, I judged, windows smashing, persons being murdered, crows squawking, and deriding, and cursing, canaries screeching, monkeys jabbering, macaws blaspheming, and every now and then fiendish bursts of laughter and explosions of dynamite. By midnight I had suffered all the different kinds of shocks there are, and knew that I could never more be disturbed by them, either isolated or in combination. Then came peace—stillness deep and solemn and lasted till five.

Then it all broke loose again. And who re-started it? The Bird of Birds the Indian crow. I came to know him well, by and by, and be infatuated with him. I suppose he is the hardest lot that wears feathers. Yes, and the cheerfulest, and the best satisfied with himself. He never arrived at what he is by any careless process, or any sudden one; he is a work of art, and "art is long"; he is the product of immemorial ages, and of deep calculation; one can't make a bird like that in a day. He has been reincarnated more times than Shiva; and he has kept a sample of each incarnation, and fused it into his constitution. In the course of his evolutionary promotions, his sublime march toward ultimate perfection, he has been a gambler, a low comedian, a dissolute priest, a fussy woman, a blackguard, a scoffer, a liar, a thief, a spy, an informer, a trading politician, a swindler, a professional hypocrite, a patriot for cash, a reformer, a lecturer, a lawyer, a conspirator, a rebel, a royalist, a democrat, a practicer and propagator of irreverence, a meddler, an intruder, a busybody, an infidel, and a wallower in sin for the mere love of it. The strange result, the incredible result, of this patient accumulation of all damnable traits is, that he does not know what care is, he does not know what sorrow is, he does not know what remorse is, his life is one long thundering ecstasy of happiness, and he will go to his death untroubled, knowing that he will soon turn up again as an author or something, and be even more intolerably capable and comfortable than ever he was before.

In his straddling wide forward-step, and his springy side-wise series of hops, and his impudent air, and his cunning way of canting his head to one side upon occasion, he reminds one of the American blackbird. But the sharp resemblances stop there. He is much bigger than the blackbird; and he lacks the blackbird's trim and slender and beautiful build and shapely beak; and of course his sober garb of gray and rusty black is a poor and humble thing compared with the splendid lustre of the blackbird's metallic sables and shifting and flashing bronze glories. The blackbird is a perfect gentleman, in deportment and attire, and is not noisy, I believe, except when holding religious services and political conventions in a tree; but this Indian sham Quaker is just a rowdy, and is always noisy when awake—always chaffing, scolding, scoffing, laughing, ripping, and cursing, and carrying on about something or other. I never saw such a bird for delivering opinions. Nothing escapes him; he notices everything that happens, and brings out his opinion about it, particularly if it is a matter that is none of his business. And it is never a mild opinion, but always violent—violent and profane—the presence of ladies does not affect him. His opinions are not the outcome of reflection, for he never thinks about anything, but heaves out the opinion that is on top in his mind, and which is often an opinion about some quite different thing and does not fit the case. But that is his way; his main idea is to get out an opinion, and if he stopped to think he would lose chances.

I suppose he has no enemies among men. The whites and Mohammedans never seemed to molest him; and the Hindoos, because of their religion, never take the life of any creature, but spare even the snakes and tigers and fleas and

rats.

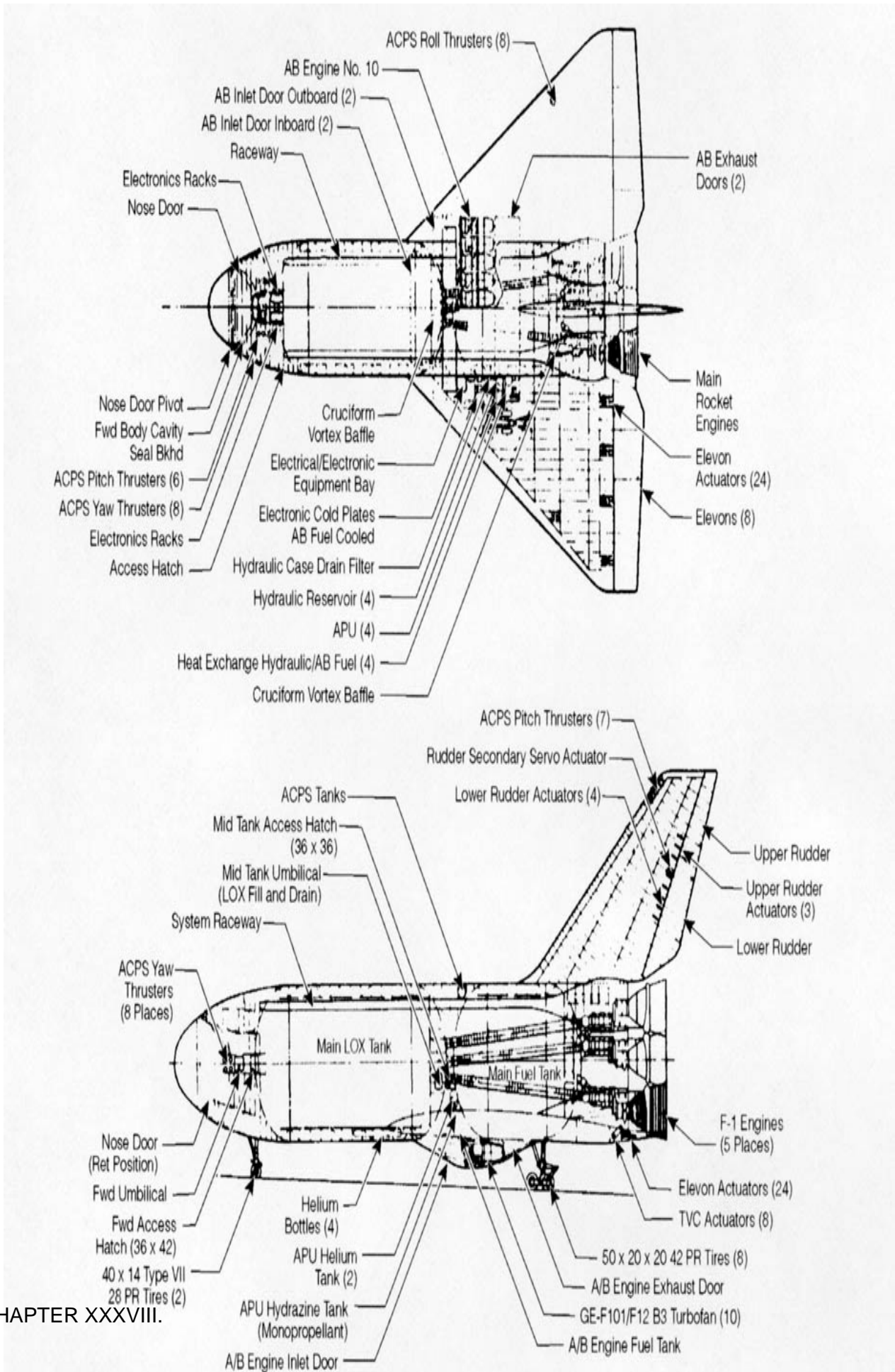

If I sat on one end of the balcony, the crows would gather on the railing at the other end and talk about me; and edge closer, little by little, till I could almost reach them; and they would sit there, in the most unabashed way, and talk about my clothes, and my hair, and my complexion, and probable character and vocation and politics, and how I came to be in India, and what I had been doing, and how many days I had got for it, and how I had happened to go unhanged so long, and when would it probably come off, and might there be more of my sort where I came from, and when would they be hanged,—and so on, and so on, until I could not longer endure the embarrassment of it; then I would shoo them away, and they would circle around in the air a little while, laughing and deriding and mocking, and presently settle on the rail and do it all over again.

They were very sociable when there was anything to eat—oppressively so. With a little encouragement they would come in and light on the table and help me eat my breakfast; and once when I was in the other room and they found themselves alone, they carried off everything they could lift; and they were particular to choose things which they could make no use of after they got them. In India their number is beyond estimate, and their noise is in proportion. I suppose they cost the country more than the government does; yet that is not a light matter. Still, they pay; their company pays; it would sadden the land to take their cheerful voice out of it.



*** END OF THE PROJECT GUTENBERG EBOOK FOLLOWING THE EQUATOR, V4 ***

***** This file should be named mt4eq10h.html or mt4eq10h.zip *****

Corrected EDITIONS of our eBooks get a new NUMBER, mt4eq11h.html

VERSIONS based on separate sources get new LETTER, mt4eq10ha.html

This eBook was produced by David Widger [widger@cecomet.net]

Project Gutenberg eBooks are often created from several printed

Following the Equator, Illustrated, v4

editions, all of which are confirmed as Public Domain in the US unless a copyright notice is included. Thus, we usually do not keep eBooks in compliance with any particular paper edition.

We are now trying to release all our eBooks one year in advance of the official release dates, leaving time for better editing. Please be encouraged to tell us about any error or corrections, even years after the official publication date.

Please note neither this listing nor its contents are final til midnight of the last day of the month of any such announcement. The official release date of all Project Gutenberg eBooks is at Midnight, Central Time, of the last day of the stated month. A preliminary version may often be posted for suggestion, comment and editing by those who wish to do so.

Most people start at our Web sites at:

<http://gutenberg.net> or

<http://promo.net/pg>

These Web sites include award-winning information about Project Gutenberg, including how to donate, how to help produce our new eBooks, and how to subscribe to our email newsletter (free!).

Those of you who want to download any eBook before announcement can get to them as follows, and just download by date. This is also a good way to get them instantly upon announcement, as the indexes our cataloguers produce obviously take a while after an announcement goes out in the Project Gutenberg Newsletter.

Following the Equator, Illustrated, v4

<http://www.ibiblio.org/gutenberg/etext03> or

<ftp://ftp.ibiblio.org/pub/docs/books/gutenberg/etext03>

Or /etext02, 01, 00, 99, 98, 97, 96, 95, 94, 93, 92, 91 or 90

Just search by the first five letters of the filename you want,
as it appears in our Newsletters.

Information about Project Gutenberg (one page)

We produce about two million dollars for each hour we work. The time it takes us, a rather conservative estimate, is fifty hours to get any eBook selected, entered, proofread, edited, copyright searched and analyzed, the copyright letters written, etc. Our projected audience is one hundred million readers. If the value per text is nominally estimated at one dollar then we produce \$2 million dollars per hour in 2002 as we release over 100 new text files per month: 1240 more eBooks in 2001 for a total of 4000+ We are already on our way to trying for 2000 more eBooks in 2002 If they reach just 1-2% of the world's population then the total will reach over half a trillion eBooks given away by year's end.

The Goal of Project Gutenberg is to Give Away 1 Trillion eBooks!
This is ten thousand titles each to one hundred million readers,
which is only about 4% of the present number of computer users.

Here is the briefest record of our progress (* means estimated):

eBooks Year Month

Following the Equator, Illustrated, v4

1 1971 July
10 1991 January
100 1994 January
1000 1997 August
1500 1998 October
2000 1999 December
2500 2000 December
3000 2001 November
4000 2001 October/November
6000 2002 December*
9000 2003 November*
10000 2004 January*

The Project Gutenberg Literary Archive Foundation has been created to secure a future for Project Gutenberg into the next millennium.

We need your donations more than ever!

As of February, 2002, contributions are being solicited from people and organizations in: Alabama, Alaska, Arkansas, Connecticut, Delaware, District of Columbia, Florida, Georgia, Hawaii, Illinois, Indiana, Iowa, Kansas, Kentucky, Louisiana, Maine, Massachusetts, Michigan, Mississippi, Missouri, Montana, Nebraska, Nevada, New Hampshire, New Jersey, New Mexico, New York, North Carolina, Ohio, Oklahoma, Oregon, Pennsylvania, Rhode Island, South Carolina, South Dakota, Tennessee, Texas, Utah, Vermont, Virginia, Washington, West Virginia, Wisconsin, and Wyoming.

We have filed in all 50 states now, but these are the only ones that have responded.

Following the Equator, Illustrated, v4

As the requirements for other states are met, additions to this list will be made and fund raising will begin in the additional states. Please feel free to ask to check the status of your state.

In answer to various questions we have received on this:

We are constantly working on finishing the paperwork to legally request donations in all 50 states. If your state is not listed and you would like to know if we have added it since the list you have, just ask.

While we cannot solicit donations from people in states where we are not yet registered, we know of no prohibition against accepting donations from donors in these states who approach us with an offer to donate.

International donations are accepted, but we don't know ANYTHING about how to make them tax-deductible, or even if they CAN be made deductible, and don't have the staff to handle it even if there are ways.

Donations by check or money order may be sent to:

Project Gutenberg Literary Archive Foundation
PMB 113
1739 University Ave.
Oxford, MS 38655-4109

Contact us if you want to arrange for a wire transfer or payment method other than by check or money order.

Following the Equator, Illustrated, v4

The Project Gutenberg Literary Archive Foundation has been approved by the US Internal Revenue Service as a 501(c)(3) organization with EIN [Employee Identification Number] 64-622154. Donations are tax-deductible to the maximum extent permitted by law. As fund-raising requirements for other states are met, additions to this list will be made and fund-raising will begin in the additional states.

We need your donations more than ever!

You can get up to date donation information online at:

<http://www.gutenberg.net/donation.html>

If you can't reach Project Gutenberg,
you can always email directly to:

Michael S. Hart [hart@pobox.com]

Prof. Hart will answer or forward your message.

We would prefer to send you information by email.

The Legal Small Print

(Three Pages)

Following the Equator, Illustrated, v4

START**THE SMALL PRINT!**FOR PUBLIC DOMAIN EBOOKS**START

Why is this "Small Print!" statement here? You know: lawyers. They tell us you might sue us if there is something wrong with your copy of this eBook, even if you got it for free from someone other than us, and even if what's wrong is not our fault. So, among other things, this "Small Print!" statement disclaims most of our liability to you. It also tells you how you may distribute copies of this eBook if you want to.

BEFORE! YOU USE OR READ THIS EBOOK

By using or reading any part of this PROJECT GUTENBERG-tm eBook, you indicate that you understand, agree to and accept this "Small Print!" statement. If you do not, you can receive a refund of the money (if any) you paid for this eBook by sending a request within 30 days of receiving it to the person you got it from. If you received this eBook on a physical medium (such as a disk), you must return it with your request.

ABOUT PROJECT GUTENBERG-TM EBOOKS

This PROJECT GUTENBERG-tm eBook, like most PROJECT GUTENBERG-tm eBooks, is a "public domain" work distributed by Professor Michael S. Hart through the Project Gutenberg Association (the "Project"). Among other things, this means that no one owns a United States copyright on or for this work, so the Project (and you!) can copy and distribute it in the United States without permission and without paying copyright royalties. Special rules, set forth below, apply if you wish to copy and distribute this eBook under the "PROJECT GUTENBERG" trademark.

Please do not use the "PROJECT GUTENBERG" trademark to market

Following the Equator, Illustrated, v4

any commercial products without permission.

To create these eBooks, the Project expends considerable efforts to identify, transcribe and proofread public domain works. Despite these efforts, the Project's eBooks and any medium they may be on may contain "Defects". Among other things, Defects may take the form of incomplete, inaccurate or corrupt data, transcription errors, a copyright or other intellectual property infringement, a defective or damaged disk or other eBook medium, a computer virus, or computer codes that damage or cannot be read by your equipment.

LIMITED WARRANTY; DISCLAIMER OF DAMAGES

But for the "Right of Replacement or Refund" described below, [1] Michael Hart and the Foundation (and any other party you may receive this eBook from as a PROJECT GUTENBERG-tm eBook) disclaims all liability to you for damages, costs and expenses, including legal fees, and [2] YOU HAVE NO REMEDIES FOR NEGLIGENCE OR UNDER STRICT LIABILITY, OR FOR BREACH OF WARRANTY OR CONTRACT, INCLUDING BUT NOT LIMITED TO INDIRECT, CONSEQUENTIAL, PUNITIVE OR INCIDENTAL DAMAGES, EVEN IF YOU GIVE NOTICE OF THE POSSIBILITY OF SUCH DAMAGES.

If you discover a Defect in this eBook within 90 days of receiving it, you can receive a refund of the money (if any) you paid for it by sending an explanatory note within that time to the person you received it from. If you received it on a physical medium, you must return it with your note, and such person may choose to alternatively give you a replacement copy. If you received it electronically, such person may choose to alternatively give you a second opportunity to

Following the Equator, Illustrated, v4

receive it electronically.

THIS EBOOK IS OTHERWISE PROVIDED TO YOU "AS-IS". NO OTHER WARRANTIES OF ANY KIND, EXPRESS OR IMPLIED, ARE MADE TO YOU AS TO THE EBOOK OR ANY MEDIUM IT MAY BE ON, INCLUDING BUT NOT LIMITED TO WARRANTIES OF MERCHANTABILITY OR FITNESS FOR A PARTICULAR PURPOSE.

Some states do not allow disclaimers of implied warranties or the exclusion or limitation of consequential damages, so the above disclaimers and exclusions may not apply to you, and you may have other legal rights.

INDEMNITY

You will indemnify and hold Michael Hart, the Foundation, and its trustees and agents, and any volunteers associated with the production and distribution of Project Gutenberg-tm texts harmless, from all liability, cost and expense, including legal fees, that arise directly or indirectly from any of the following that you do or cause: [1] distribution of this eBook, [2] alteration, modification, or addition to the eBook, or [3] any Defect.

DISTRIBUTION UNDER "PROJECT GUTENBERG-tm"

You may distribute copies of this eBook electronically, or by disk, book or any other medium if you either delete this "Small Print!" and all other references to Project Gutenberg, or:

[1] Only give exact copies of it. Among other things, this requires that you do not remove, alter or modify the

Following the Equator, Illustrated, v4

eBook or this "small print!" statement. You may however, if you wish, distribute this eBook in machine readable binary, compressed, mark-up, or proprietary form, including any form resulting from conversion by word processing or hypertext software, but only so long as

***EITHER*:**

[*] The eBook, when displayed, is clearly readable, and does ***not*** contain characters other than those intended by the author of the work, although tilde (~), asterisk (*) and underline (_) characters may be used to convey punctuation intended by the author, and additional characters may be used to indicate hypertext links; OR

[*] The eBook may be readily converted by the reader at no expense into plain ASCII, EBCDIC or equivalent form by the program that displays the eBook (as is the case, for instance, with most word processors); OR

[*] You provide, or agree to also provide on request at no additional cost, fee or expense, a copy of the eBook in its original plain ASCII form (or in EBCDIC or other equivalent proprietary form).

[2] Honor the eBook refund and replacement provisions of this "Small Print!" statement.

[3] Pay a trademark license fee to the Foundation of 20% of the gross profits you derive calculated using the method you

Following the Equator, Illustrated, v4

already use to calculate your applicable taxes. If you don't derive profits, no royalty is due. Royalties are payable to "Project Gutenberg Literary Archive Foundation" the 60 days following each date you prepare (or were legally required to prepare) your annual (or equivalent periodic) tax return. Please contact us beforehand to let us know your plans and to work out the details.

WHAT IF YOU *WANT* TO SEND MONEY EVEN IF YOU DON'T HAVE TO?

Project Gutenberg is dedicated to increasing the number of public domain and licensed works that can be freely distributed in machine readable form.

The Project gratefully accepts contributions of money, time, public domain materials, or royalty free copyright licenses.

Money should be paid to the:

"Project Gutenberg Literary Archive Foundation."

If you are interested in contributing scanning equipment or software or other items, please contact Michael Hart at:
hart@pobox.com

[Portions of this eBook's header and trailer may be reprinted only when distributed free of all fees. Copyright (C) 2001, 2002 by Michael S. Hart. Project Gutenberg is a TradeMark and may not be used in any sales of Project Gutenberg eBooks or other materials be they hardware or software or any other related product without express permission.]

*END THE SMALL PRINT! FOR PUBLIC DOMAIN EBOOKS*Ver.02/11/02*END*

