

The Gilded Age, Illustrated, Volume 2.

Mark Twain (Samuel Clemens) and Charles Dudley Warner

Table of Contents

<u>The Gilded Age, Illustrated, Volume 2</u>	1
<u>Mark Twain (Samuel Clemens) and Charles Dudley Warner</u>	2
<u>CONTENTS</u>	9
<u>ILLUSTRATIONS</u>	11
<u>CHAPTER X</u>	13
<u>CHAPTER XI</u>	19
<u>CHAPTER XII</u>	23
<u>CHAPTER XIII</u>	28
<u>CHAPTER XIV</u>	34
<u>CHAPTER XV</u>	39
<u>CHAPTER XVI</u>	47
<u>CHAPTER XVII</u>	56
<u>CHAPTER XVIII</u>	63

The Gilded Age, Illustrated, Volume 2.

Mark Twain (Samuel Clemens) and Charles Dudley Warner

This page copyright © 2002 Blackmask Online.
<http://www.blackmask.com>

- CONTENTS
- ILLUSTRATIONS
- CHAPTER X.
- CHAPTER XI.
- CHAPTER XII.
- CHAPTER XIII.
- CHAPTER XIV.
- CHAPTER XV.
- CHAPTER XVI.
- CHAPTER XVII.
- CHAPTER XVIII.

This etext was produced by David Widger widger@cecomet.net

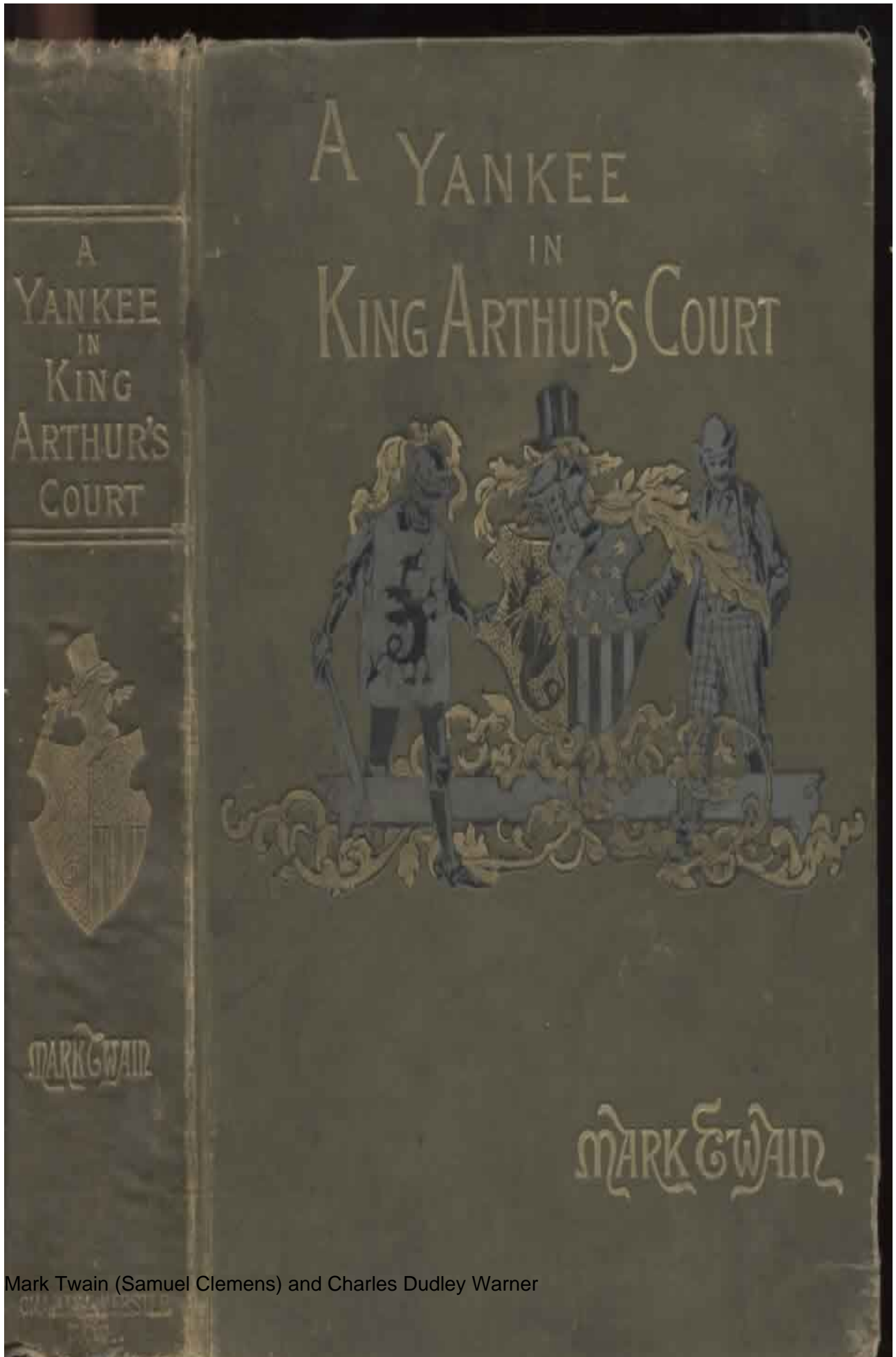

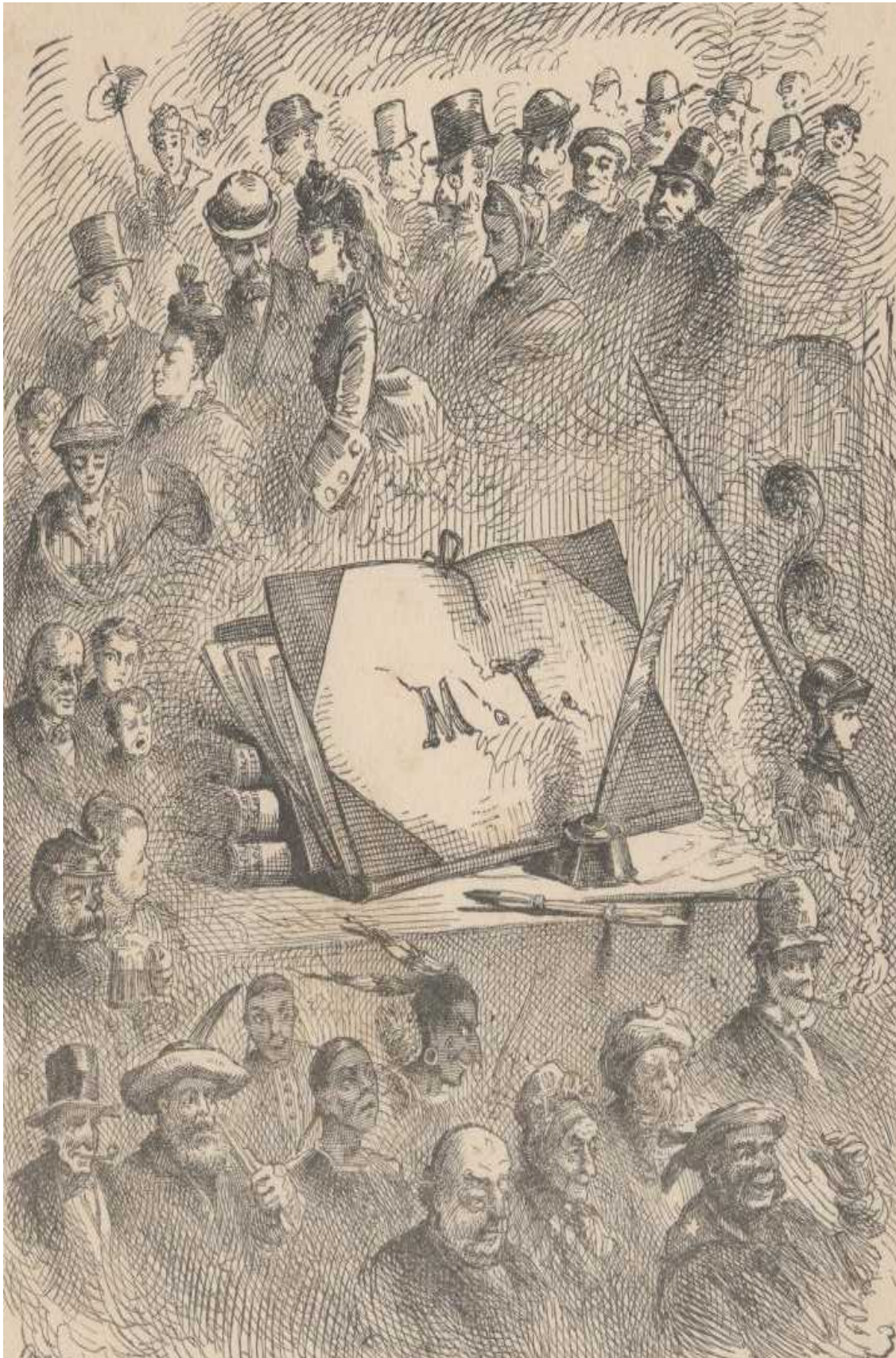

A CONNECTICUT YANKEE
IN
KING ARTHUR'S COURT.

BY
MARK TWAIN.

NEW YORK:
CHARLES L. WEBSTER & COMPANY.

CONTENTS

CHAPTER X

Laura Hawkins Discovers a Mystery in Her Parentage and Grows Morbid Under the Village Gossip

CHAPTER XI

A Dinner with Col Sellers—Wonderful Effects of Raw Turnips

CHAPTER XII

Philip Sterling and Henry Brierly—Arrangements to Go West as Engineers

CHAPTER XIII

Rail—Road Contractors and Party Traveling—Philip and Harry form the Acquaintance of Col Sellers

CHAPTER XIV

Ruth Bolton and Her Parents

CHAPTER XV

Visitors of the Boltons—Mr Bigler "Sees the Legislature"—Ruth Bolton Commences Medical Studies

CHAPTER XVI

The Engineers Detained at St Louis—Off for Camp—Reception by Jeff

CHAPTER XVII

The Engineer Corps Arrive at Stone's Landing

The Gilded Age, Illustrated, Volume 2.

CHAPTER XVIII

Laura and Her Marriage to Colonel Selby—Deserted and Returns to Hawkeye

ILLUSTRATIONS

- 37 LAURA SEEKING FOR EVIDENCES OF HER BIRTH
- 38 EVER TRUE
- 39 A HEALTHY MEAL
- 40 PHILIP AT THE THEATRE
- 41 WHAT PHILIP LEARNED AT COLLEGE
- 42 THE DELEGATE'S INTERESTING GAME
- 43 THE PERSON OF IMPORTANCE
- 44 "NOT THAT"
- 45 RUTH'S MOTHER MAKES ENQUIRIES
- 46 THE LETTER
- 47 CARING FOR THE POOR
- 48 ANATOMICAL INVESTIGATIONS
- 49 RUTH LOOKING AT THE "NEW ONE" BY CANDLE LIGHT
- 60 "ONLY FOR YOU, BRIERLY"
- 51 AN ACCLIMATED MAN
- 51 NO THANKS! GOOD BYE!
- 52 "BRESS YOU, CHILE, YOU DAR NOW"
- 53 CAMP LIFE
- 54 STRAIGHT FROM THE SHOULDER
- 55 JEFF THOMPSON AS A NIGHTINGALE
- 56 BOUND FOR STONE'S LANDING
- 57 STONE'S LANDING
- 58 WAITING FOR A RAILROAD
- 59 "IT AIN'T THERE"
- 60 TAIL PIECE
- 61 CAPTURE OF WASHINGTON
- 63 LAURA SWOONED
- 62 TAILPIECE

CHAPTER X.

Only two or three days had elapsed since the funeral, when something happened which was to change the drift of Laura's life somewhat, and influence in a greater or lesser degree the formation of her character.

Major Lackland had once been a man of note in the State—a man of extraordinary natural ability and as extraordinary learning. He had been universally trusted and honored in his day, but had finally, fallen into misfortune; while serving his third term in Congress, and while upon the point of being elevated to the Senate—which was considered the summit of earthly aggrandizement in those days—he had yielded to temptation, when in distress for money wherewith to save his estate; and sold his vote. His crime was discovered, and his fall followed instantly. Nothing could reinstate him in the confidence of the people, his ruin was irretrievable—his disgrace complete. All doors were closed against him, all men avoided him. After years of skulking retirement and dissipation, death had relieved him of his troubles at last, and his funeral followed close upon that of Mr. Hawkins. He died as he had latterly lived—wholly alone and friendless. He had no relatives—or if he had they did not acknowledge him. The coroner's jury found certain memoranda upon his body and about the premises which revealed a fact not suspected by the villagers before—viz., that Laura was not the child of Mr. and Mrs. Hawkins.

The gossips were soon at work. They were but little hampered by the fact that the memoranda referred to betrayed nothing but the bare circumstance that Laura's real parents were unknown, and stopped there. So far from being hampered by this, the gossips seemed to gain all the more freedom from it. They supplied all the missing information themselves, they filled up all the blanks. The town soon teemed with histories of Laura's origin and secret history, no two versions precisely alike, but all elaborate, exhaustive, mysterious and interesting, and all agreeing in one vital particular—to-wit, that there was a suspicious cloud about her birth, not to say a disreputable one.

Laura began to encounter cold looks, averted eyes and peculiar nods and gestures which perplexed her beyond measure; but presently the pervading gossip found its way to her, and she understood them—then. Her pride was stung. She was astonished, and at first incredulous. She was about to ask her mother if there was any truth in these reports, but upon second thought held her peace. She soon gathered that Major Lackland's memoranda seemed to refer to letters which had passed between himself and Judge Hawkins. She shaped her course without difficulty the day that that hint reached her.

That night she sat in her room till all was still, and then she stole into the garret and began a search. She rummaged long among boxes of musty papers relating to business matters of no, interest to her, but at last she found several bundles of letters. One bundle was marked "private," and in that she found what she wanted. She selected six or eight letters from the package and began to devour their contents, heedless of the cold.



By the dates, these letters were from five to seven years old. They were all from Major Lackland to Mr. Hawkins. The substance of them was, that some one in the east had been inquiring of Major Lackland about a lost child and its parents, and that it was conjectured that the child might be Laura.

Evidently some of the letters were missing, for the name of the inquirer was not mentioned; there was a casual reference to "this handsome—featured aristocratic gentleman," as if the reader and the writer were accustomed to speak of him and knew who was meant.

In one letter the Major said he agreed with Mr. Hawkins that the inquirer seemed not altogether on the wrong track; but he also agreed that it would be best to keep quiet until more convincing developments were forthcoming.

Another letter said that "the poor soul broke completely down when he saw Laura's picture, and declared it must be she."

Still another said:

"He seems entirely alone in the world, and his heart is so wrapped up in this thing that I believe that if it proved a false hope, it would kill him; I have persuaded him to wait a little while and go west when I go."

Another letter had this paragraph in it:

"He is better one day and worse the next, and is out of his mind a good deal of the time. Lately his case has developed a something which is a wonder to the hired nurses, but which will not be much of a marvel to you if you have read medical philosophy much. It is this: his lost memory returns to him when he is delirious, and goes away again when he is himself—just as old Canada Joe used to talk the French patois of his boyhood in the delirium of typhus fever, though he could not do it when his mind was clear. Now this poor gentleman's memory has always broken down before he reached the explosion of the steamer; he could only remember starting up the river with his wife and child, and he had an idea that there was a race, but he was not certain; he could not name the boat he was on; there was a dead blank of a month or more that supplied not an item to his recollection. It was not for me to assist him, of course. But now in his delirium it all comes out: the names of the boats, every incident of the explosion, and likewise the details of his astonishing escape—that is, up to where, just as a yawl-boat was approaching him (he was clinging to the starboard wheel of the burning wreck at the time), a falling timber struck him on the head. But I will write out his wonderful escape in full to-morrow or next day. Of course the physicians will not let me tell him now that our Laura is indeed his child—that must come later, when his health is thoroughly restored. His case is not considered dangerous at all; he will recover presently, the doctors say. But they insist that he must travel a little when he gets well—they recommend a short sea voyage, and they say he can be persuaded to try it if we continue to keep him in ignorance and promise to let him see L. as soon as he returns."

The letter that bore the latest date of all, contained this clause:

"It is the most unaccountable thing in the world; the mystery remains as impenetrable as ever; I have hunted high and low for him, and inquired of everybody, but in vain; all trace of him ends at that hotel in New York; I never have seen or heard of him since, up to this day; he could hardly have sailed, for his name does not appear upon the books of any shipping office in New York or

The Gilded Age, Illustrated, Volume 2.

Boston or Baltimore. How fortunate it seems, now, that we kept this thing to ourselves; Laura still has a father in you, and it is better for her that we drop this subject here forever."

That was all. Random remarks here and there, being pieced together gave Laura a vague impression of a man of fine presence, about forty-three or forty-five years of age, with dark hair and eyes, and a slight limp in his walk—it was not stated which leg was defective. And this indistinct shadow represented her father. She made an exhaustive search for the missing letters, but found none. They had probably been burned; and she doubted not that the ones she had ferreted out would have shared the same fate if Mr. Hawkins had not been a dreamer, void of method, whose mind was perhaps in a state of conflagration over some bright new speculation when he received them.

She sat long, with the letters in her lap, thinking—and unconsciously freezing. She felt like a lost person who has traveled down a long lane in good hope of escape, and, just as the night descends finds his progress barred by a bridge-less river whose further shore, if it has one, is lost in the darkness. If she could only have found these letters a month sooner! That was her thought. But now the dead had carried their secrets with them. A dreary, melancholy settled down upon her. An undefined sense of injury crept into her heart. She grew very miserable.

She had just reached the romantic age—the age when there is a sad sweetness, a dismal comfort to a girl to find out that there is a mystery connected with her birth, which no other piece of good luck can afford. She had more than her rightful share of practical good sense, but still she was human; and to be human is to have one's little modicum of romance secreted away in one's composition. One never ceases to make a hero of one's self, (in private,) during life, but only alters the style of his heroism from time to time as the drifting years belittle certain gods of his admiration and raise up others in their stead that seem greater.

The recent wearing days and nights of watching, and the wasting grief that had possessed her, combined with the profound depression that naturally came with the reaction of idleness, made Laura peculiarly susceptible at this time to romantic impressions. She was a heroine, now, with a mysterious father somewhere. She could not really tell whether she wanted to find him and spoil it all or not; but still all the traditions of romance pointed to the making the attempt as the usual and necessary, course to follow; therefore she would some day begin the search when opportunity should offer.

Now a former thought struck her—she would speak to Mrs. Hawkins. And naturally enough Mrs. Hawkins appeared on the stage at that moment.

She said she knew all—she knew that Laura had discovered the secret that Mr. Hawkins, the elder children, Col. Sellers and herself had kept so long and so faithfully; and she cried and said that now that troubles had begun they would never end; her daughter's love would wean itself away from her and her heart would break. Her grief so wrought upon Laura that the girl almost forgot her own troubles for the moment in her compassion for her mother's distress. Finally Mrs. Hawkins said:

"Speak to me, child—do not forsake me. Forget all this miserable talk. Say I am your mother!—I have loved you so long, and there is no other. I am your mother, in the sight of God, and nothing shall ever take you from me!"

All barriers fell, before this appeal. Laura put her arms about her mother's neck and said:

"You are my mother, and always shall be. We will be as we have always been; and neither this foolish talk nor any other thing shall part us or make us less to each other than we are this hour."



There was no longer any sense of separation or estrangement between them. Indeed their love seemed more perfect now than it had ever been before. By and by they went down stairs and sat by the fire and talked long and earnestly about Laura's history and the letters. But it transpired that Mrs. Hawkins had never known of this correspondence between her husband and Major Lackland. With his usual consideration for his wife, Mr. Hawkins had shielded her from the worry the matter would have caused her.

Laura went to bed at last with a mind that had gained largely in tranquility and had lost correspondingly in morbid romantic exaltation. She was pensive, the next day, and subdued; but that was not matter for remark, for she did not differ from the mournful friends about her in that respect. Clay and Washington were the same loving and admiring brothers now that they had always been. The great secret was new to some of the younger children, but their love suffered no change under the wonderful revelation.

It is barely possible that things might have presently settled down into their old rut and the mystery have lost the bulk of its romantic sublimity in Laura's eyes, if the village gossips could have quieted down. But they could not quiet down and they did not. Day after day they called at the house, ostensibly upon visits of condolence, and they pumped away at the mother and the children without seeming to know that their questionings were in bad taste. They meant no harm they only wanted to know. Villagers always want to know.

The family fought shy of the questionings, and of course that was high testimony "if the Duchess was respectably born, why didn't they come out and prove it?—why did they, stick to that poor thin story about picking her up out of a steamboat explosion?"

Under this ceaseless persecution, Laura's morbid self-communing was renewed. At night the day's contribution of detraction, innuendo and malicious conjecture would be canvassed in her mind, and then she

would drift into a course of thinking. As her thoughts ran on, the indignant tears would spring to her eyes, and she would spit out fierce little ejaculations at intervals. But finally she would grow calmer and say some comforting disdainful thing—something like this:

"But who are they?—Animals! What are their opinions to me? Let them talk—I will not stoop to be affected by it. I could hate——. Nonsense—nobody I care for or in any way respect is changed toward me, I fancy."

She may have supposed she was thinking of many individuals, but it was not so—she was thinking of only one. And her heart warmed somewhat, too, the while. One day a friend overheard a conversation like this:— and naturally came and told her all about it:

"Ned, they say you don't go there any more. How is that?"

"Well, I don't; but I tell you it's not because I don't want to and it's not because I think it is any matter who her father was or who he wasn't, either; it's only on account of this talk, talk, talk. I think she is a fine girl every way, and so would you if you knew her as well as I do; but you know how it is when a girl once gets talked about—it's all up with her—the world won't ever let her alone, after that."

The only comment Laura made upon this revelation, was:

"Then it appears that if this trouble had not occurred I could have had the happiness of Mr. Ned Thurston's serious attentions. He is well favored in person, and well liked, too, I believe, and comes of one of the first families of the village. He is prosperous, too, I hear; has been a doctor a year, now, and has had two patients—no, three, I think; yes, it was three. I attended their funerals. Well, other people have hoped and been disappointed; I am not alone in that. I wish you could stay to dinner, Maria—we are going to have sausages; and besides, I wanted to talk to you about Hawkeye and make you promise to come and see us when we are settled there."

But Maria could not stay. She had come to mingle romantic tears with Laura's over the lover's defection and had found herself dealing with a heart that could not rise to an appreciation of affliction because its interest was all centred in sausages.

But as soon as Maria was gone, Laura stamped her expressive foot and said:

"The coward! Are all books lies? I thought he would fly to the front, and be brave and noble, and stand up for me against all the world, and defy my enemies, and wither these gossips with his scorn! Poor crawling thing, let him go. I do begin to despise thin world!"

She lapsed into thought. Presently she said:

"If the time ever comes, and I get a chance, Oh, I'll——"

She could not find a word that was strong enough, perhaps. By and by she said:

"Well, I am glad of it—I'm glad of it. I never cared anything for him anyway!"

And then, with small consistency, she cried a little, and patted her foot more indignantly than ever.

CHAPTER XI.

Two months had gone by and the Hawkins family were domiciled in Hawkeye. Washington was at work in the real estate office again, and was alternately in paradise or the other place just as it happened that Louise was gracious to him or seemingly indifferent—because indifference or preoccupation could mean nothing else than that she was thinking of some other young person. Col. Sellers had asked him several times, to dine with him, when he first returned to Hawkeye, but Washington, for no particular reason, had not accepted. No particular reason except one which he preferred to keep to himself—viz. that he could not bear to be away from Louise. It occurred to him, now, that the Colonel had not invited him lately—could he be offended? He resolved to go that very day, and give the Colonel a pleasant surprise. It was a good idea; especially as Louise had absented herself from breakfast that morning, and torn his heart; he would tear hers, now, and let her see how it felt.

The Sellers family were just starting to dinner when Washington burst upon them with his surprise. For an instant the Colonel looked nonplussed, and just a bit uncomfortable; and Mrs. Sellers looked actually distressed; but the next moment the head of the house was himself again, and exclaimed:

"All right, my boy, all right—always glad to see you—always glad to hear your voice and take you by the hand. Don't wait for special invitations—that's all nonsense among friends. Just come whenever you can, and come as often as you can—the oftener the better. You can't please us any better than that, Washington; the little woman will tell you so herself. We don't pretend to style. Plain folks, you know—plain folks. Just a plain family dinner, but such as it is, our friends are always welcome, I reckon you know that yourself, Washington. Run along, children, run along; Lafayette,—[**In those old days the average man called his children after his most revered literary and historical idols; consequently there was hardly a family, at least in the West, but had a Washington in it—and also a Lafayette, a Franklin, and six or eight sounding names from Byron, Scott, and the Bible, if the offspring held out. To visit such a family, was to find one's self confronted by a congress made up of representatives of the imperial myths and the majestic dead of all the ages. There was something thrilling about it, to a stranger, not to say awe inspiring.]—stand off the cat's tail, child, can't you see what you're doing?—Come, come, come, Roderick Dhu, it isn't nice for little boys to hang onto young gentlemen's coat tails— but never mind him, Washington, he's full of spirits and don't mean any harm. Children will be children, you know. Take the chair next to Mrs. Sellers, Washington—tut, tut, Marie Antoinette, let your brother have the fork if he wants it, you are bigger than he is."

Washington contemplated the banquet, and wondered if he were in his right mind. Was this the plain family dinner? And was it all present? It was soon apparent that this was indeed the dinner: it was all on the table: it consisted of abundance of clear, fresh water, and a basin of raw turnips—nothing more.



Washington stole a glance at Mrs. Sellers's face, and would have given the world, the next moment, if he could have spared her that. The poor woman's face was crimson, and the tears stood in her eyes. Washington did not know what to do. He wished he had never come there and spied out this cruel poverty and brought pain to that poor little lady's heart and shame to her cheek; but he was there, and there was no escape. Col. Sellers hitched back his coat sleeves airily from his wrists as who should say "Now for solid enjoyment!" seized a fork, flourished it and began to harpoon turnips and deposit them in the plates before him "Let me help you, Washington—Lafayette pass this plate Washington—ah, well, well, my boy, things are looking pretty bright, now, I tell you. Speculation—my! the whole atmosphere's full of money. I wouldn't take three fortunes for one little operation I've got on hand now—have anything from the casters? No? Well, you're right, you're right. Some people like mustard with turnips, but—now there was Baron Poniatowski— Lord, but that man did know how to live!—true Russian you know, Russian to the back bone; I say to my wife, give me a Russian every time, for a table comrade. The Baron used to say, 'Take mustard, Sellers, try the mustard,—a man can't know what turnips are in perfection without, mustard,' but I always said, 'No, Baron, I'm a plain man and I want my food plain—none of your embellishments for Beriah Sellers—no made dishes for me! And it's the best way—high living kills more than it cures in this world, you can rest assured of that.—Yes indeed, Washington, I've got one little operation on hand that—take some more water—help yourself, won't you?—help yourself, there's plenty of it. —You'll find it pretty good, I guess. How does that fruit strike you?"

Washington said he did not know that he had ever tasted better. He did not add that he detested turnips even when they were cooked loathed them in their natural state. No, he kept this to himself, and praised the turnips to the peril of his soul.

"I thought you'd like them. Examine them—examine them—they'll bear it. See how perfectly firm and juicy

they are—they can't start any like them in this part of the country, I can tell you. These are from New Jersey—I imported them myself. They cost like sin, too; but lord bless me, I go in for having the best of a thing, even if it does cost a little more—it's the best economy, in the long run. These are the Early Malcolm—it's a turnip that can't be produced except in just one orchard, and the supply never is up to the demand. Take some more water, Washington—you can't drink too much water with fruit—all the doctors say that. The plague can't come where this article is, my boy!"

"Plague? What plague?"

"What plague, indeed? Why the Asiatic plague that nearly depopulated London a couple of centuries ago."

"But how does that concern us? There is no plague here, I reckon."

"Sh! I've let it out! Well, never mind—just keep it to yourself. Perhaps I oughtn't said anything, but its bound to come out sooner or later, so what is the odds? Old McDowells wouldn't like me to—to—bother it all, I'll just tell the whole thing and let it go. You see, I've been down to St. Louis, and I happened to run across old Dr. McDowells—thinks the world of me, does the doctor. He's a man that keeps himself to himself, and well he may, for he knows that he's got a reputation that covers the whole earth—he won't condescend to open himself out to many people, but lord bless you, he and I are just like brothers; he won't let me go to a hotel when I'm in the city—says I'm the only man that's company to him, and I don't know but there's some truth in it, too, because although I never like to glorify myself and make a great to-do over what I am or what I can do or what I know, I don't mind saying here among friends that I am better read up in most sciences, maybe, than the general run of professional men in these days. Well, the other day he let me into a little secret, strictly on the quiet, about this matter of the plague.

"You see it's booming right along in our direction—follows the Gulf Stream, you know, just as all those epidemics do, and within three months it will be just waltzing through this land like a whirlwind! And whoever it touches can make his will and contract for the funeral. Well you can't cure it, you know, but you can prevent it. How? Turnips! that's it! Turnips and water! Nothing like it in the world, old McDowells says, just fill yourself up two or three times a day, and you can snap your fingers at the plague. Sh!—keep mum, but just you confine yourself to that diet and you're all right. I wouldn't have old McDowells know that I told about it for anything—he never would speak to me again. Take some more water, Washington—the more water you drink, the better. Here, let me give you some more of the turnips. No, no, no, now, I insist. There, now. Absorb those. They're, mighty sustaining—brim full of nutriment—all the medical books say so. Just eat from four to seven good-sized turnips at a meal, and drink from a pint and a half to a quart of water, and then just sit around a couple of hours and let them ferment. You'll feel like a fighting cock next day."

Fifteen or twenty minutes later the Colonel's tongue was still chattering away—he had piled up several future fortunes out of several incipient "operations" which he had blundered into within the past week, and was now soaring along through some brilliant expectations born of late promising experiments upon the lacking ingredient of the eye-water. And at such a time Washington ought to have been a rapt and enthusiastic listener, but he was not, for two matters disturbed his mind and distracted his attention. One was, that he discovered, to his confusion and shame, that in allowing himself to be helped a second time to the turnips, he had robbed those hungry children. He had not needed the dreadful "fruit," and had not wanted it; and when he saw the pathetic sorrow in their faces when they asked for more and there was no more to give them, he hated himself for his stupidity and pitied the famishing young things with all his heart. The other matter that disturbed him was the dire inflation that had begun in his stomach. It grew and grew, it became more and more insupportable. Evidently the turnips were "fermenting." He forced himself to sit still as long as he could, but his anguish conquered him at last.

He rose in the midst of the Colonel's talk and excused himself on the plea of a previous engagement. The Colonel followed him to the door, promising over and over again that he would use his influence to get some of the Early Malcolms for him, and insisting that he should not be such a stranger but come and take pot-luck with him every chance he got. Washington was glad enough to get away and feel free again. He immediately bent his steps toward home.

In bed he passed an hour that threatened to turn his hair gray, and then a blessed calm settled down upon him that filled his heart with gratitude. Weak and languid, he made shift to turn himself about and seek rest and sleep; and as his soul hovered upon the brink of unconciousness, he heaved a long, deep sigh, and said to himself that in his heart he had cursed the Colonel's preventive of rheumatism, before, and now let the plague come if it

The Gilded Age, Illustrated, Volume 2.

must—he was done with preventives; if ever any man beguiled him with turnips and water again, let him die the death.

If he dreamed at all that night, no gossiping spirit disturbed his visions to whisper in his ear of certain matters just then in bud in the East, more than a thousand miles away that after the lapse of a few years would develop influences which would profoundly affect the fate and fortunes of the Hawkins family.

CHAPTER XII.

"Oh, it's easy enough to make a fortune," Henry said.

"It seems to be easier than it is, I begin to think," replied Philip.

"Well, why don't you go into something? You'll never dig it out of the Astor Library."

If there be any place and time in the world where and when it seems easy to "go into something" it is in Broadway on a spring morning, when one is walking city-ward, and has before him the long lines of palace-shops with an occasional spire seen through the soft haze that lies over the lower town, and hears the roar and hum of its multitudinous traffic.

To the young American, here or elsewhere, the paths to fortune are innumerable and all open; there is invitation in the air and success in all his wide horizon. He is embarrassed which to choose, and is not unlikely to waste years in dallying with his chances, before giving himself to the serious tug and strain of a single object. He has no traditions to bind him or guide him, and his impulse is to break away from the occupation his father has followed, and make a new way for himself.

Philip Sterling used to say that if he should seriously set himself for ten years to any one of the dozen projects that were in his brain, he felt that he could be a rich man. He wanted to be rich, he had a sincere desire for a fortune, but for some unaccountable reason he hesitated about addressing himself to the narrow work of getting it. He never walked Broadway, a part of its tide of abundant shifting life, without feeling something of the flush of wealth, and unconsciously taking the elastic step of one well-to-do in this prosperous world.

Especially at night in the crowded theatre—Philip was too young to remember the old Chambers' Street box, where the serious Burton led his hilarious and pagan crew—in the intervals of the screaming comedy, when the orchestra scraped and grunted and tooted its dissolute tunes, the world seemed full of opportunities to Philip, and his heart exulted with a conscious ability to take any of its prizes he chose to pluck.

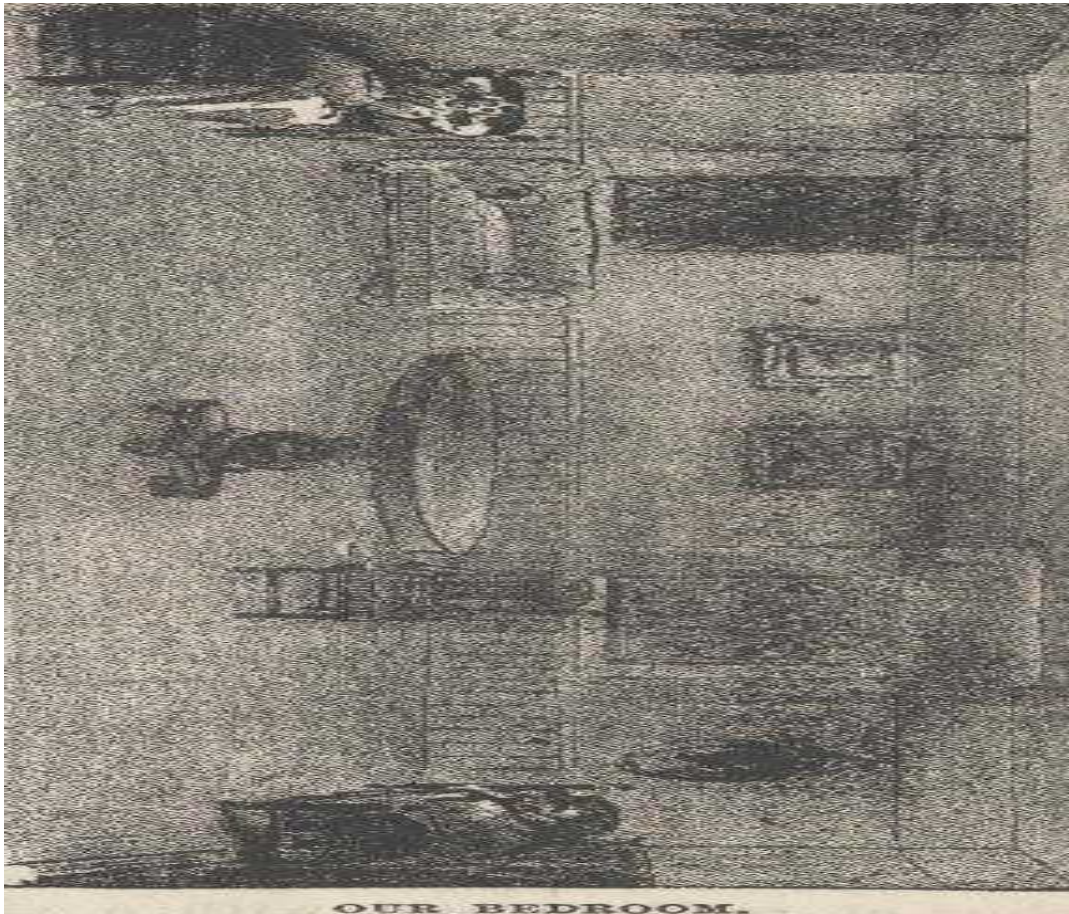

Perhaps it was the swimming ease of the acting, on the stage, where virtue had its reward in three easy acts, perhaps it was the excessive light of the house, or the music, or the buzz of the excited talk between acts, perhaps it was youth which believed everything, but for some reason while Philip was at the theatre he had the utmost confidence in life and his ready victory in it.

Delightful illusion of paint and tinsel and silk attire, of cheap sentiment and high and mighty dialogue! Will there not always be rosin enough for the squeaking fiddle-bow?

Do we not all like the maudlin hero, who is sneaking round the right entrance, in wait to steal the pretty wife of his rich and tyrannical neighbor from the paste-board cottage at the left entrance? and when he advances down to the foot-lights and defiantly informs the audience that, "he who lays his hand on a woman except in the way of kindness," do we not all applaud so as to drown the rest of the sentence?

Philip never was fortunate enough to hear what would become of a man who should lay his hand on a woman with the exception named; but he learned afterwards that the woman who lays her hand on a man, without any exception whatsoever, is always acquitted by the jury.

The fact was, though Philip Sterling did not know it, that he wanted several other things quite as much as he wanted wealth. The modest fellow would have liked fame thrust upon him for some worthy achievement; it might be for a book, or for the skillful management of some great newspaper, or for some daring expedition like that of Lt. Strain or Dr. Kane. He was unable to decide exactly what it should be. Sometimes he thought he would like to stand in a conspicuous pulpit and humbly preach the gospel of repentance; and it even crossed his mind that it would be noble to give himself to a missionary life to some benighted region, where the date-palm grows, and the nightingale's voice is in tune, and the bul-bul sings on the off nights. If he were good enough he would attach himself to that company of young men in the Theological Seminary, who were seeing New York life in

preparation for the ministry.

Philip was a New England boy and had graduated at Yale; he had not carried off with him all the learning of that venerable institution, but he knew some things that were not in the regular course of study. A very good use of the English language and considerable knowledge of its literature was one of them; he could sing a song very well, not in time to be sure, but with enthusiasm; he could make a magnetic speech at a moment's notice in the class room, the debating society, or upon any fence or dry-goods box that was convenient; he could lift himself by one arm, and do the giant swing in the gymnasium; he could strike out from his left shoulder; he could handle an oar like a professional and pull stroke in a winning race. Philip had a good appetite, a sunny temper, and a clear hearty laugh. He had brown hair, hazel eyes set wide apart, a broad but not high forehead, and a fresh winning face. He was six feet high, with broad shoulders, long legs and a swinging gait; one of those loose-jointed, capable fellows, who saunter into the world with a free air and usually make a stir in whatever company they enter.

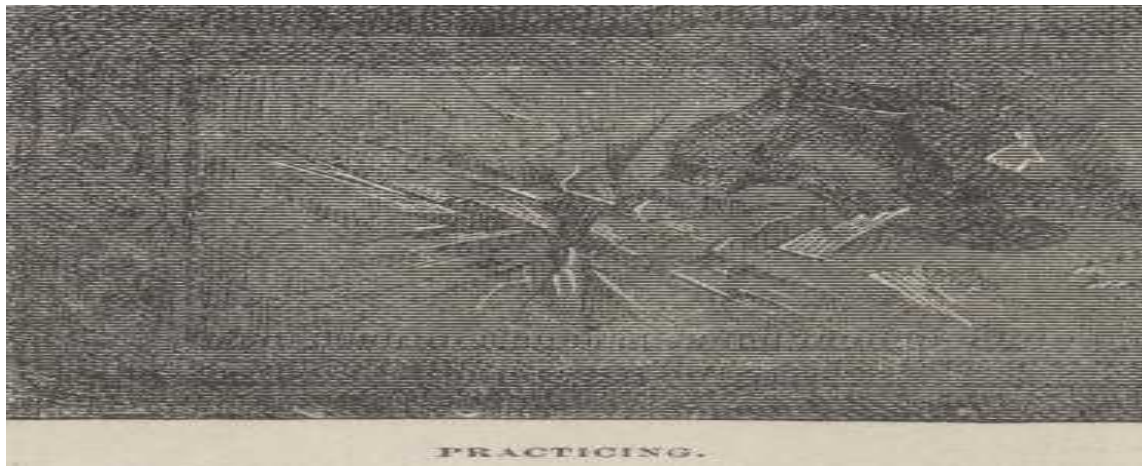

After he left college Philip took the advice of friends and read law. Law seemed to him well enough as a science, but he never could discover a practical case where it appeared to him worth while to go to law, and all the clients who stopped with this new clerk in the ante-room of the law office where he was writing, Philip invariably advised to settle—no matter how, but settle—greatly to the disgust of his employer, who knew that justice between man and man could only be attained by the recognized processes, with the attendant fees. Besides Philip hated the copying of pleadings, and he was certain that a life of "whereases" and "aforesaid" and whipping the devil round the stump, would be intolerable.

[Note: these few paragraphs are nearly an autobiography of the life of Charles Dudley Warner whose contributions to the story start here with Chapter XII. D.W.]

His pen therefore, and whereas, and not as aforesaid, strayed off into other scribbling. In an unfortunate hour, he had two or three papers accepted by first-class magazines, at three dollars the printed page, and, behold, his vocation was open to him. He would make his mark in literature.

Life has no moment so sweet as that in which a young man believes himself called into the immortal ranks of the masters of literature. It is such a noble ambition, that it is a pity it has usually such a shallow foundation.

At the time of this history, Philip had gone to New York for a career. With his talent he thought he should have little difficulty in getting an editorial position upon a metropolitan newspaper; not that he knew anything about news paper work, or had the least idea of journalism; he knew he was not fitted for the technicalities of the subordinate departments, but he could write leaders with perfect ease, he was sure. The drudgery of the newspaper office was too distaste ful, and besides it would be beneath the dignity of a graduate and a successful

magazine writer. He wanted to begin at the top of the ladder.

To his surprise he found that every situation in the editorial department of the journals was full, always had been full, was always likely to be full. It seemed to him that the newspaper managers didn't want genius, but mere plodding and grubbing. Philip therefore read diligently in the Astor library, planned literary works that should compel attention, and nursed his genius. He had no friend wise enough to tell him to step into the Dorking Convention, then in session, make a sketch of the men and women on the platform, and take it to the editor of the Daily Grapevine, and see what he could get a line for it.

One day he had an offer from some country friends, who believed in him, to take charge of a provincial daily newspaper, and he went to consult Mr. Gringo—Gringo who years ago managed the Atlas—about taking the situation.

"Take it of course," says Gringo, take anything that offers, why not?"

"But they want me to make it an opposition paper."

"Well, make it that. That party is going to succeed, it's going to elect the next president."

"I don't believe it," said Philip, stoutly, "its wrong in principle, and it ought not to succeed, but I don't see how I can go for a thing I don't believe in."

"O, very well," said Gringo, turning away with a shade of contempt, "you'll find if you are going into literature and newspaper work that you can't afford a conscience like that."

But Philip did afford it, and he wrote, thanking his friends, and declining because he said the political scheme would fail, and ought to fail. And he went back to his books and to his waiting for an opening large enough for his dignified entrance into the literary world.

It was in this time of rather impatient waiting that Philip was one morning walking down Broadway with Henry Brierly. He frequently accompanied Henry part way down town to what the latter called his office in Broad Street, to which he went, or pretended to go, with regularity every day. It was evident to the most casual acquaintance that he was a man of affairs, and that his time was engrossed in the largest sort of operations, about which there was a mysterious air. His liability to be suddenly summoned to Washington, or Boston or Montreal or even to Liverpool was always imminent. He never was so summoned, but none of his acquaintances would have been surprised to hear any day that he had gone to Panama or Peoria, or to hear from him that he had bought the Bank of Commerce.

The two were intimate at that time,—they had been class, mates—and saw a great deal of each other. Indeed, they lived together in Ninth Street, in a boarding-house, there, which had the honor of lodging and partially feeding several other young fellows of like kidney, who have since gone their several ways into fame or into obscurity.

It was during the morning walk to which reference has been made that Henry Brierly suddenly said, "Philip, how would you like to go to St. Jo?"

"I think I should like it of all things," replied Philip, with some hesitation, "but what for."

"Oh, it's a big operation. We are going, a lot of us, railroad men, engineers, contractors. You know my uncle is a great railroad man. I've no doubt I can get you a chance to go if you'll go."

"But in what capacity would I go?"

"Well, I'm going as an engineer. You can go as one."

"I don't know an engine from a coal cart."

"Field engineer, civil engineer. You can begin by carrying a rod, and putting down the figures. It's easy enough. I'll show you about that. We'll get Trautwine and some of those books."

"Yes, but what is it for, what is it all about?"

"Why don't you see? We lay out a line, spot the good land, enter it up, know where the stations are to be, spot them, buy lots; there's heaps of money in it. We wouldn't engineer long."

"When do you go?" was Philip's next question, after some moments of silence.

"To-morrow. Is that too soon?"

"No, its not too soon. I've been ready to go anywhere for six months. The fact is, Henry, that I'm about tired of trying to force myself into things, and am quite willing to try floating with the stream for a while, and see where I will land. This seems like a providential call; it's sudden enough."

The two young men who were by this time full of the adventure, went down to the Wall street office of Henry's

uncle and had a talk with that wily operator. The uncle knew Philip very well, and was pleased with his frank enthusiasm, and willing enough to give him a trial in the western venture. It was settled therefore, in the prompt way in which things are settled in New York, that they would start with the rest of the company next morning for the west.

On the way up town these adventurers bought books on engineering, and suits of India-rubber, which they supposed they would need in a new and probably damp country, and many other things which nobody ever needed anywhere.

The night was spent in packing up and writing letters, for Philip would not take such an important step without informing his friends. If they disapprove, thought he, I've done my duty by letting them know. Happy youth, that is ready to pack its valise, and start for Cathay on an hour's notice.

"By the way," calls out Philip from his bed-room, to Henry, "where is St. Jo.?"

"Why, it's in Missouri somewhere, on the frontier I think. We'll get a map."

"Never mind the map. We will find the place itself. I was afraid it was nearer home."

Philip wrote a long letter, first of all, to his mother, full of love and glowing anticipations of his new opening. He wouldn't bother her with business details, but he hoped that the day was not far off when she would see him return, with a moderate fortune, and something to add to the comfort of her advancing years.

To his uncle he said that he had made an arrangement with some New York capitalists to go to Missouri, in a land and railroad operation, which would at least give him a knowledge of the world and not unlikely offer him a business opening. He knew his uncle would be glad to hear that he had at last turned his thoughts to a practical matter.

It was to Ruth Bolton that Philip wrote last. He might never see her again; he went to seek his fortune. He well knew the perils of the frontier, the savage state of society, the lurking Indians and the dangers of fever. But there was no real danger to a person who took care of himself. Might he write to her often and, tell her of his life. If he returned with a fortune, perhaps and perhaps. If he was unsuccessful, or if he never returned—perhaps it would be as well. No time or distance, however, would ever lessen his interest in her. He would say good-night, but not good-bye.

In the soft beginning of a Spring morning, long before New York had breakfasted, while yet the air of expectation hung about the wharves of the metropolis, our young adventurers made their way to the Jersey City railway station of the Erie road, to begin the long, swinging, crooked journey, over what a writer of a former day called a causeway of cracked rails and cows, to the West.

CHAPTER XIII.

What ever to say be toke in his entente,
his langage was so fayer & pertynante,
yt semeth unto manys heryng not only the worde,
but veryly the thyng.
Caxton's Book of Curtesye.

In the party of which our travelers found themselves members, was Duff Brown, the great railroad contractor, and subsequently a well-known member of Congress; a bluff, jovial Bost'n man, thick-set, close shaven, with a heavy jaw and a low forehead—a very pleasant man if you were not in his way. He had government contracts also, custom houses and dry docks, from Portland to New Orleans, and managed to get out of congress, in appropriations, about weight for weight of gold for the stone furnished.

Associated with him, and also of this party, was Rodney Schaick, a sleek New York broker, a man as prominent in the church as in the stock exchange, dainty in his dress, smooth of speech, the necessary complement of Duff Brown in any enterprise that needed assurance and adroitness.

It would be difficult to find a pleasanter traveling party one that shook off more readily the artificial restraints of Puritanic strictness, and took the world with good-natured allowance. Money was plenty for every attainable luxury, and there seemed to be no doubt that its supply would continue, and that fortunes were about to be made without a great deal of toil. Even Philip soon caught the prevailing spirit; Barry did not need any inoculation, he always talked in six figures. It was as natural for the dear boy to be rich as it is for most people to be poor.

The elders of the party were not long in discovering the fact, which almost all travelers to the west soon find out; that the water was poor. It must have been by a lucky premonition of this that they all had brandy flasks with which to qualify the water of the country; and it was no doubt from an uneasy feeling of the danger of being poisoned that they kept experimenting, mixing a little of the dangerous and changing fluid, as they passed along, with the contents of the flasks, thus saving their lives hour by hour. Philip learned afterwards that temperance and the strict observance of Sunday and a certain gravity of deportment are geographical habits, which people do not usually carry with them away from home.

Our travelers stopped in Chicago long enough to see that they could make their fortunes there in two week's time, but it did not seem worth while; the west was more attractive; the further one went the wider the opportunities opened.

They took railroad to Alton and the steamboat from there to St. Louis, for the change and to have a glimpse of the river.

"Isn't this jolly?" cried Henry, dancing out of the barber's room, and coming down the deck with a one, two, three step, shaven, curled and perfumed after his usual exquisite fashion.

"What's jolly?" asked Philip, looking out upon the dreary and monotonous waste through which the shaking steamboat was coughing its way.

"Why, the whole thing; it's immense I can tell you. I wouldn't give that to be guaranteed a hundred thousand cold cash in a year's time."

"Where's Mr. Brown?"

"He is in the saloon, playing poker with Schaick and that long haired party with the striped trousers, who scrambled aboard when the stage plank was half hauled in, and the big Delegate to Congress from out west."

"That's a fine looking fellow, that delegate, with his glossy, black whiskers; looks like a Washington man; I shouldn't think he'd be at poker."

"Oh, its only five cent ante, just to make it interesting, the Delegate said."

"But I shouldn't think a representative in Congress would play poker any way in a public steamboat."



"Nonsense, you've got to pass the time. I tried a hand myself, but those old fellows are too many for me. The Delegate knows all the points. I'd bet a hundred dollars he will ante his way right into the United States Senate when his territory comes in. He's got the cheek for it."

"He has the grave and thoughtful manner of expectoration of a public man, for one thing," added Philip.

"Harry," said Philip, after a pause, "what have you got on those big boots for; do you expect to wade ashore?"

"I'm breaking 'em in."

The fact was Harry had got himself up in what he thought a proper costume for a new country, and was in appearance a sort of compromise between a dandy of Broadway and a backwoodsman. Harry, with blue eyes, fresh complexion, silken whiskers and curly chestnut hair, was as handsome as a fashion plate. He wore this morning a soft hat, a short cutaway coat, an open vest displaying immaculate linen, a leathern belt round his waist, and top-boots of soft leather, well polished, that came above his knees and required a string attached to his belt to keep them up. The light hearted fellow gloried in these shining encasements of his well shaped legs, and told Philip that they were a perfect protection against prairie rattle-snakes, which never strike above the knee.

The landscape still wore an almost wintry appearance when our travelers left Chicago. It was a genial spring day when they landed at St. Louis; the birds were singing, the blossoms of peach trees in city garden plots, made the air sweet, and in the roar and tumult on the long river levee they found an excitement that accorded with their own hopeful anticipations.

The party went to the Southern Hotel, where the great Duff Brown was very well known, and indeed was a man of so much importance that even the office clerk was respectful to him. He might have respected in him also a certain vulgar swagger and insolence of money, which the clerk greatly admired.

The young fellows liked the house and liked the city; it seemed to them a mighty free and hospitable town. Coming from the East they were struck with many peculiarities. Everybody smoked in the streets, for one thing, they noticed; everybody "took a drink" in an open manner whenever he wished to do so or was asked, as if the habit needed no concealment or apology. In the evening when they walked about they found people sitting on the door-steps of their dwellings, in a manner not usual in a northern city; in front of some of the hotels and saloons the side walks were filled with chairs and benches—Paris fashion, said Harry—upon which people lounged in these warm spring evenings, smoking, always smoking; and the clink of glasses and of billiard balls was in the air. It was delightful.

Harry at once found on landing that his back-woods custom would not be needed in St. Louis, and that, in fact, he had need of all the resources of his wardrobe to keep even with the young swells of the town. But this did not much matter, for Harry was always superior to his clothes. As they were likely to be detained some time in the city, Harry told Philip that he was going to improve his time. And he did. It was an encouragement to any industrious man to see this young fellow rise, carefully dress himself, eat his breakfast deliberately, smoke his cigar tranquilly, and then repair to his room, to what he called his work, with a grave and occupied manner, but with perfect cheerfulness.

Harry would take off his coat, remove his cravat, roll up his shirt-sleeves, give his curly hair the right touch before the glass, get out his book on engineering, his boxes of instruments, his drawing paper, his profile paper, open the book of logarithms, mix his India ink, sharpen his pencils, light a cigar, and sit down at the table to "lay out a line," with the most grave notion that he was mastering the details of engineering. He would spend half a day in these preparations without ever working out a problem or having the faintest conception of the use of lines or logarithms. And when he had finished, he had the most cheerful confidence that he had done a good day's work.

It made no difference, however, whether Harry was in his room in a hotel or in a tent, Philip soon found, he was just the same. In camp he would get himself, up in the most elaborate toilet at his command, polish his long boots to the top, lay out his work before him, and spend an hour or longer, if anybody was looking at him, humming airs, knitting his brows, and "working" at engineering; and if a crowd of gaping rustics were looking on all the while it was perfectly satisfactory to him.

"You see," he says to Philip one morning at the hotel when he was thus engaged, "I want to get the theory of this thing, so that I can have a check on the engineers."

"I thought you were going to be an engineer yourself," queried Philip.

"Not many times, if the court knows herself. There's better game. Brown and Schaick have, or will have, the control for the whole line of the Salt Lick Pacific Extension, forty thousand dollars a mile over the prairie, with extra for hard-pan—and it'll be pretty much all hardpan I can tell you; besides every alternate section of land on this line. There's millions in the job. I'm to have the sub-contract for the first fifty miles, and you can bet it's a soft thing."

"I'll tell you what you do, Philip," continued Larry, in a burst of generosity, "if I don't get you into my contract, you'll be with the engineers, and you jest stick a stake at the first ground marked for a depot, buy the land of the farmer before he knows where the depot will be, and we'll turn a hundred or so on that. I'll advance the money for the payments, and you can sell the lots. Schaick is going to let me have ten thousand just for a flyer in such operations."

"But that's a good deal of money."

"Wait till you are used to handling money. I didn't come out here for a bagatelle. My uncle wanted me to stay East and go in on the Mobile custom house, work up the Washington end of it; he said there was a fortune in it for a smart young fellow, but I preferred to take the chances out here. Did I tell you I had an offer from Bobbett and Fanshaw to go into their office as confidential clerk on a salary of ten thousand?"

"Why didn't you take it?" asked Philip, to whom a salary of two thousand would have seemed wealth, before he started on this journey.

"Take it? I'd rather operate on my own hook;" said Harry, in his most airy manner.

The Gilded Age, Illustrated, Volume 2.

A few evenings after their arrival at the Southern, Philip and Harry made the acquaintance of a very agreeable gentleman, whom they had frequently seen before about the hotel corridors, and passed a casual word with. He had the air of a man of business, and was evidently a person of importance.

The precipitating of this casual intercourse into the more substantial form of an acquaintanceship was the work of the gentleman himself, and occurred in this wise. Meeting the two friends in the lobby one evening, he asked them to give him the time, and added:

"Excuse me, gentlemen—strangers in St. Louis? Ah, yes—yes. From the East, perhaps? Ah; just so, just so. Eastern born myself—Virginia. Sellers is my name—Beriah Sellers.

"Ah! by the way—New York, did you say? That reminds me; just met some gentlemen from your State, a week or two ago—very prominent gentlemen—in public life they are; you must know them, without doubt. Let me see—let me see. Curious those names have escaped me. I know they were from your State, because I remember afterward my old friend Governor Shackleby said to me—fine man, is the Governor—one of the finest men our country has produced—said he, 'Colonel, how did you like those New York gentlemen?—not many such men in the world,—Colonel Sellers,' said the Governor—yes, it was New York he said—I remember it distinctly. I can't recall those names, somehow. But no matter. Stopping here, gentlemen—stopping at the Southern?"

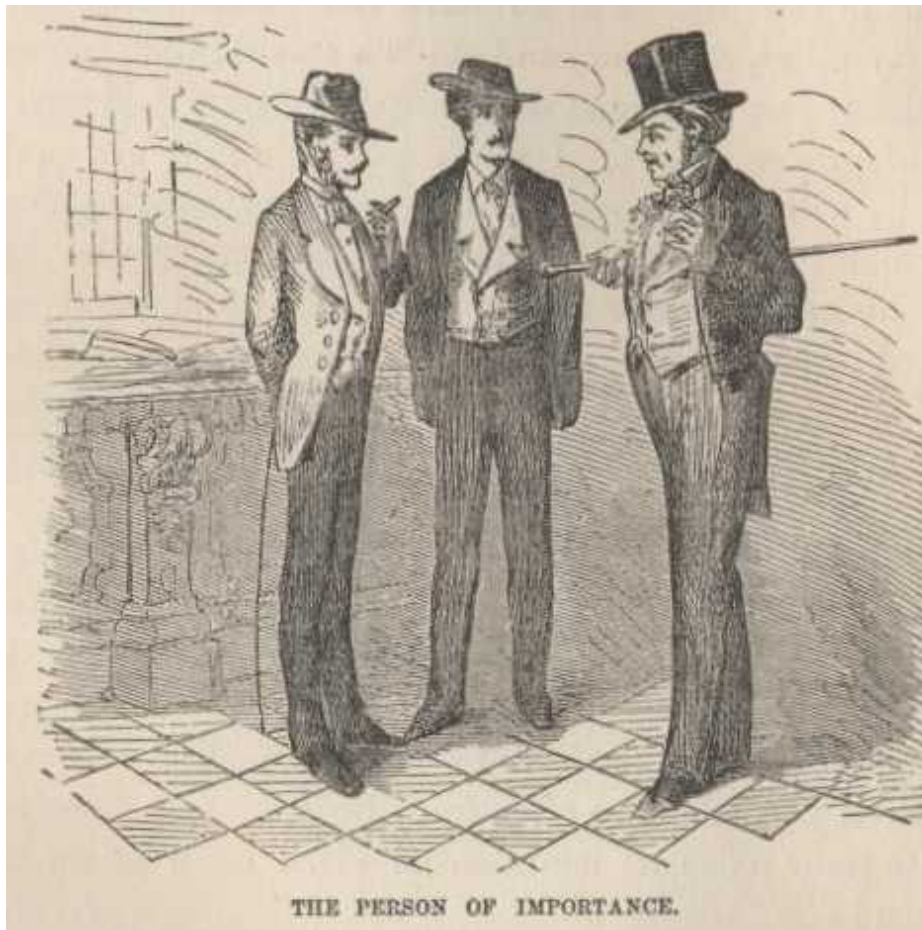

In shaping their reply in their minds, the title "Mr." had a place in it; but when their turn had arrived to speak, the title "Colonel" came from their lips instead.

They said yes, they were abiding at the Southern, and thought it a very good house.

"Yes, yes, the Southern is fair. I myself go to the Planter's, old, aristocratic house. We Southern gentlemen don't change our ways, you know. I always make it my home there when I run down from Hawkeye—my plantation is in Hawkeye, a little up in the country. You should know the Planter's."

Philip and Harry both said they should like to see a hotel that had been so famous in its day—a cheerful hostelry, Philip said it must have been where duels were fought there across the dining-room table.

"You may believe it, sir, an uncommonly pleasant lodging. Shall we walk?"

And the three strolled along the streets, the Colonel talking all the way in the most liberal and friendly manner, and with a frank open-heartedness that inspired confidence.

"Yes, born East myself, raised all along, know the West—a great country, gentlemen. The place for a young fellow of spirit to pick up a fortune, simply pick it up, it's lying round loose here. Not a day that I don't put aside an opportunity; too busy to look into it. Management of my own property takes my time. First visit? Looking for an opening?"

"Yes, looking around," replied Harry.

"Ah, here we are. You'd rather sit here in front than go to my apartments? So had I. An opening eh?"

The Colonel's eyes twinkled. "Ah, just so. The country is opening up, all we want is capital to develop it. Slap down the rails and bring the land into market. The richest land on God Almighty's footstool is lying right out there. If I had my capital free I could plant it for millions."

"I suppose your capital is largely in your plantation?" asked Philip.

"Well, partly, sir, partly. I'm down here now with reference to a little operation—a little side thing merely. By the way gentlemen, excuse the liberty, but it's about my usual time"—

The Colonel paused, but as no movement of his acquaintances followed this plain remark, he added, in an explanatory manner,

"I'm rather particular about the exact time—have to be in this climate."

Even this open declaration of his hospitable intention not being understood the Colonel politely said,

"Gentlemen, will you take something?"

Col. Sellers led the way to a saloon on Fourth street under the hotel, and the young gentlemen fell into the custom of the country.

"Not that," said the Colonel to the bar-keeper, who shoved along the counter a bottle of apparently corn-whiskey, as if he had done it before on the same order; "not that," with a wave of the hand. "That Otard if you please. Yes. Never take an inferior liquor, gentlemen, not in the evening, in this climate. There. That's the stuff. My respects!"

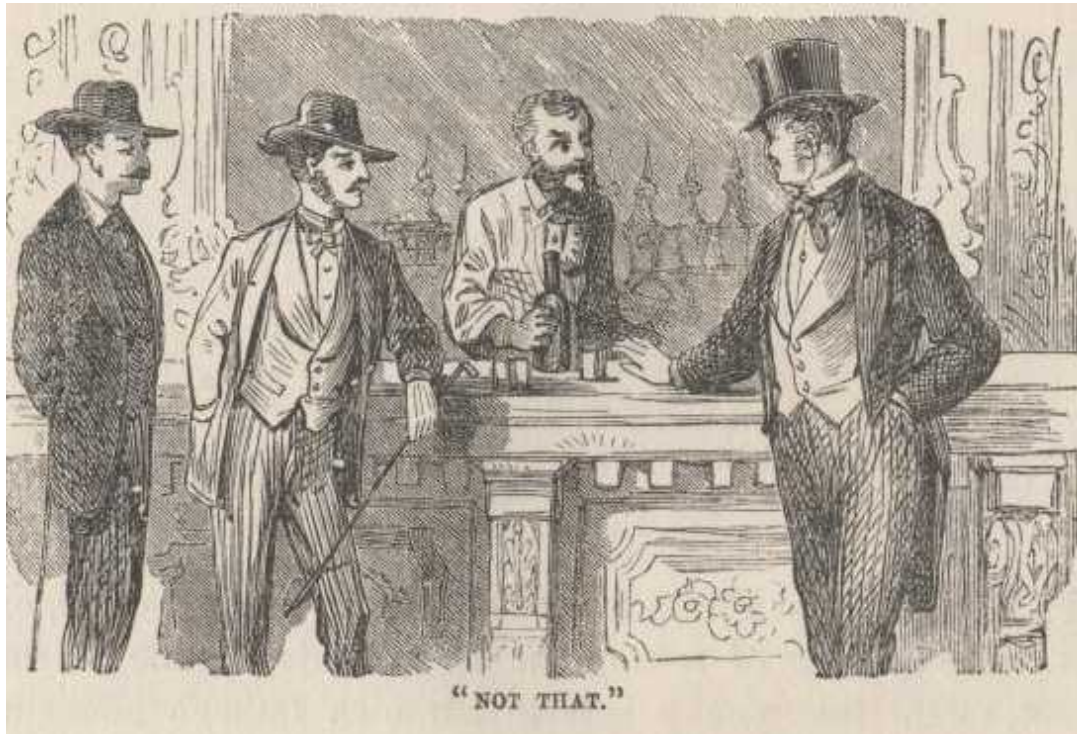

The hospitable gentleman, having disposed of his liquor, remarking that it was not quite the thing—"when a man has his own cellar to go to, he is apt to get a little fastidious about his liquors"—called for cigars. But the brand offered did not suit him; he motioned the box away, and asked for some particular Havana's, those in separate wrappers.

"I always smoke this sort, gentlemen; they are a little more expensive, but you'll learn, in this climate, that you'd better not economize on poor cigars"

Having imparted this valuable piece of information, the Colonel lighted the fragrant cigar with satisfaction, and then carelessly put his fingers into his right vest pocket. That movement being without result, with a shade of disappointment on his face, he felt in his left vest pocket. Not finding anything there, he looked up with a serious and annoyed air, anxiously slapped his right pantaloon's pocket, and then his left, and exclaimed,

"By George, that's annoying. By George, that's mortifying. Never had anything of that kind happen to me before. I've left my pocket-book. Hold! Here's a bill, after all. No, thunder, it's a receipt."

"Allow me," said Philip, seeing how seriously the Colonel was annoyed, and taking out his purse.

The Colonel protested he couldn't think of it, and muttered something to the barkeeper about "hanging it up," but the vender of exhilaration made no sign, and Philip had the privilege of paying the costly shot; Col. Sellers profusely apologizing and claiming the right "next time, next time."

As soon as Beriah Sellers had bade his friends good night and seen them depart, he did not retire apartments in the Planter's, but took his way to his lodgings with a friend in a distant part of the city.

CHAPTER XIV.

The letter that Philip Sterling wrote to Ruth Bolton, on the evening of setting out to seek his fortune in the west, found that young lady in her own father's house in Philadelphia. It was one of the pleasantest of the many charming suburban houses in that hospitable city, which is territorially one of the largest cities in the world, and only prevented from becoming the convenient metropolis of the country by the intrusive strip of Camden and Amboy sand which shuts it off from the Atlantic ocean. It is a city of steady thrift, the arms of which might well be the deliberate but delicious terrapin that imparts such a royal flavor to its feasts.

It was a spring morning, and perhaps it was the influence of it that made Ruth a little restless, satisfied neither with the out-doors nor the in-doors. Her sisters had gone to the city to show some country visitors Independence Hall, Girard College and Fairmount Water Works and Park, four objects which Americans cannot die peacefully, even in Naples, without having seen. But Ruth confessed that she was tired of them, and also of the Mint. She was tired of other things. She tried this morning an air or two upon the piano, sang a simple song in a sweet but slightly metallic voice, and then seating herself by the open window, read Philip's letter. Was she thinking about Philip, as she gazed across the fresh lawn over the tree tops to the Chelton Hills, or of that world which his entrance, into her tradition-bound life had been one of the means of opening to her? Whatever she thought, she was not idly musing, as one might see by the expression of her face. After a time she took up a book; it was a medical work, and to all appearance about as interesting to a girl of eighteen as the statutes at large; but her face was soon aglow over its pages, and she was so absorbed in it that she did not notice the entrance of her mother at the open door.

"Ruth?"

"Well, mother," said the young student, looking up, with a shade of impatience.

"I wanted to talk with thee a little about thy plans."



"Mother; thee knows I couldn't stand it at Westfield; the school stifled me, it's a place to turn young people into dried fruit."

"I know," said Margaret Bolton, with a half anxious smile, thee chafes against all the ways of Friends, but what will thee do? Why is thee so discontented?"

"If I must say it, mother, I want to go away, and get out of this dead level."

With a look half of pain and half of pity, her mother answered, "I am sure thee is little interfered with; thee dresses as thee will, and goes where thee pleases, to any church thee likes, and thee has music. I had a visit yesterday from the society's committee by way of discipline, because we have a piano in the house, which is against the rules."

"I hope thee told the elders that father and I are responsible for the piano, and that, much as thee loves music, thee is never in the room when it is played. Fortunately father is already out of meeting, so they can't discipline him. I heard father tell cousin Abner that he was whipped so often for whistling when he was a boy that he was determined to have what compensation he could get now."

"Thy ways greatly try me, Ruth, and all thy relations. I desire thy happiness first of all, but thee is starting out on a dangerous path. Is thy father willing thee should go away to a school of the world's people?"

"I have not asked him," Ruth replied with a look that might imply that she was one of those determined little bodies who first made up her own mind and then compelled others to make up theirs in accordance with hers.

"And when thee has got the education thee wants, and lost all relish for the society of thy friends and the ways of thy ancestors, what then?"

Ruth turned square round to her mother, and with an impassive face and not the slightest change of tone, said,

"Mother, I'm going to study medicine?"

Margaret Bolton almost lost for a moment her habitual placidity.

"Thee, study medicine! A slight frail girl like thee, study medicine! Does thee think thee could stand it six months? And the lectures, and the dissecting rooms, has thee thought of the dissecting rooms?"

"Mother," said Ruth calmly, "I have thought it all over. I know I can go through the whole, clinics, dissecting room and all. Does thee think I lack nerve? What is there to fear in a person dead more than in a person living?"

"But thy health and strength, child; thee can never stand the severe application. And, besides, suppose thee does learn medicine?"

"I will practice it."

"Here?"

"Here."

"Where thee and thy family are known?"

"If I can get patients."

"I hope at least, Ruth, thee will let us know when thee opens an office," said her mother, with an approach to sarcasm that she rarely indulged in, as she rose and left the room.

Ruth sat quite still for a time, with face intent and flushed. It was out now. She had begun her open battle.

The sight-seers returned in high spirits from the city. Was there any building in Greece to compare with Girard College, was there ever such a magnificent pile of stone devised for the shelter of poor orphans? Think of the stone shingles of the roof eight inches thick! Ruth asked the enthusiasts if they would like to live in such a sounding mausoleum, with its great halls and echoing rooms, and no comfortable place in it for the accommodation of any body? If they were orphans, would they like to be brought up in a Grecian temple?

And then there was Broad street! Wasn't it the broadest and the longest—street in the world? There certainly was no end to it, and even Ruth was Philadelphian enough to believe that a street ought not to have any end, or architectural point upon which the weary eye could rest.

But neither St. Girard, nor Broad street, neither wonders of the Mint nor the glories of the Hall where the ghosts of our fathers sit always signing the Declaration; impressed the visitors so much as the splendors of the Chestnut street windows, and the bargains on Eighth street. The truth is that the country cousins had come to town to attend the Yearly Meeting, and the amount of shopping that preceded that religious event was scarcely exceeded by the preparations for the opera in more worldly circles.

"Is thee going to the Yearly Meeting, Ruth?" asked one of the girls.

"I have nothing to wear," replied that demure person. "If thee wants to see new bonnets, orthodox to a shade and conformed to the letter of the true form, thee must go to the Arch Street Meeting. Any departure from either color or shape would be instantly taken note of. It has occupied mother a long time, to find at the shops the exact shade for her new bonnet. Oh, thee must go by all means. But thee won't see there a sweeter woman than mother."

"And thee won't go?"

"Why should I? I've been again and again. If I go to Meeting at all I like best to sit in the quiet old house in Germantown, where the windows are all open and I can see the trees, and hear the stir of the leaves. It's such a crush at the Yearly Meeting at Arch Street, and then there's the row of sleek-looking young men who line the curbstone and stare at us as we come out. No, I don't feel at home there."

That evening Ruth and her father sat late by the drawing-room fire, as they were quite apt to do at night. It was always a time of confidences.

"Thee has another letter from young Sterling," said Eli Bolton.

"Yes. Philip has gone to the far west."

"How far?"

"He doesn't say, but it's on the frontier, and on the map everything beyond it is marked 'Indians' and 'desert,' and looks as desolate as a Wednesday Meeting."

"Humph. It was time for him to do something. Is he going to start a daily newspaper among the Kick-a-poops?"

"Father, thee's unjust to Philip. He's going into business."

"What sort of business can a young man go into without capital?"

"He doesn't say exactly what it is," said Ruth a little dubiously, "but it's something about land and railroads,

and thee knows, father, that fortunes are made nobody knows exactly how, in a new country."

"I should think so, you innocent puss, and in an old one too. But Philip is honest, and he has talent enough, if he will stop scribbling, to make his way. But thee may as well take care of theeself, Ruth, and not go dawdling along with a young man in his adventures, until thy own mind is a little more settled what thee wants."

This excellent advice did not seem to impress Ruth greatly, for she was looking away with that abstraction of vision which often came into her grey eyes, and at length she exclaimed, with a sort of impatience,

"I wish I could go west, or south, or somewhere. What a box women are put into, measured for it, and put in young; if we go anywhere it's in a box, veiled and pinioned and shut in by disabilities. Father, I should like to break things and get loose!"

What a sweet-voiced little innocent, it was to be sure.

"Thee will no doubt break things enough when thy time comes, child; women always have; but what does thee want now that thee hasn't?"

"I want to be something, to make myself something, to do something. Why should I rust, and be stupid, and sit in inaction because I am a girl? What would happen to me if thee should lose thy property and die? What one useful thing could I do for a living, for the support of mother and the children? And if I had a fortune, would thee want me to lead a useless life?"

"Has thy mother led a useless life?"

"Somewhat that depends upon whether her children amount to anything," retorted the sharp little disputant. "What's the good, father, of a series of human beings who don't advance any?"

Friend Eli, who had long ago laid aside the Quaker dress, and was out of Meeting, and who in fact after a youth of doubt could not yet define his belief, nevertheless looked with some wonder at this fierce young eagle of his, hatched in a Friend's dove-cote. But he only said,

"Has thee consulted thy mother about a career, I suppose it is a career thee wants?"

Ruth did not reply directly; she complained that her mother didn't understand her. But that wise and placid woman understood the sweet rebel a great deal better than Ruth understood herself. She also had a history, possibly, and had sometime beaten her young wings against the cage of custom, and indulged in dreams of a new social order, and had passed through that fiery period when it seems possible for one mind, which has not yet tried its limits, to break up and re-arrange the world.

Ruth replied to Philip's letter in due time and in the most cordial and unsentimental manner. Philip liked the letter, as he did everything she did; but he had a dim notion that there was more about herself in the letter than about him. He took it with him from the Southern Hotel, when he went to walk, and read it over and again in an unfrequented street as he stumbled along. The rather common-place and unformed hand-writing seemed to him peculiar and characteristic, different from that of any other woman.

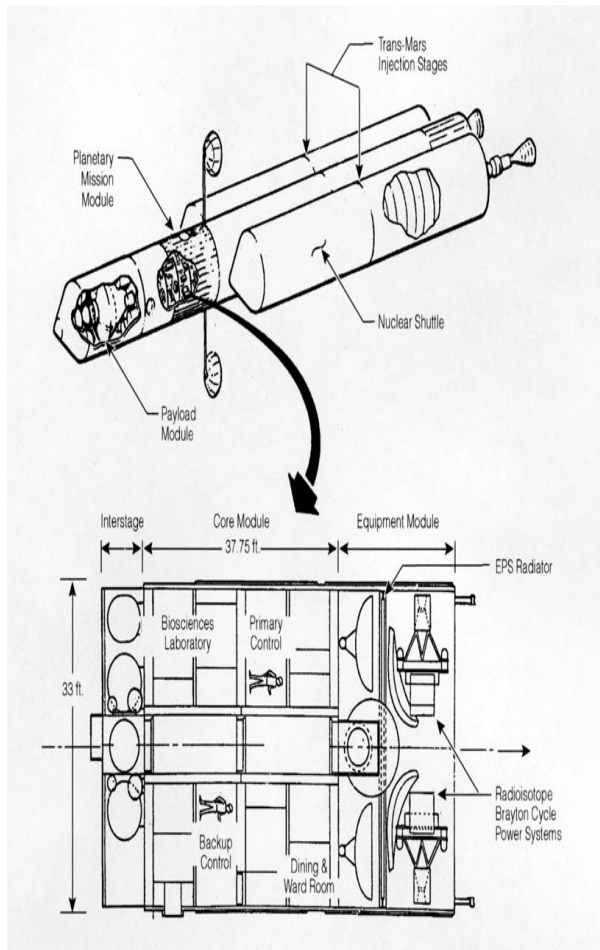

Ruth was glad to hear that Philip had made a push into the world, and she was sure that his talent and courage would make a way for him. She should pray for his success at any rate, and especially that the Indians, in St. Louis, would not take his scalp.

Philip looked rather dubious at this sentence, and wished that he had written nothing about Indians.

CHAPTER XV.

Eli Bolton and his wife talked over Ruth's case, as they had often done before, with no little anxiety. Alone of all their children she was impatient of the restraints and monotony of the Friends' Society, and wholly indisposed to accept the "inner light" as a guide into a life of acceptance and inaction. When Margaret told her husband of Ruth's newest project, he did not exhibit so much surprise as she hoped for. In fact he said that he did not see why a woman should not enter the medical profession if she felt a call to it.

"But," said Margaret, "consider her total inexperience of the world, and her frail health. Can such a slight little body endure the ordeal of the preparation for, or the strain of, the practice of the profession?"

"Did thee ever think, Margaret, whether, she can endure being thwarted in an, object on which she has so set her heart, as she has on this? Thee has trained her thyself at home, in her enfeebled childhood, and thee knows how strong her will is, and what she has been able to accomplish in self-culture by the simple force of her determination. She never will be satisfied until she has tried her own strength."

"I wish," said Margaret, with an inconsequence that is not exclusively feminine, "that she were in the way to fall in love and marry by and by. I think that would cure her of some of her notions. I am not sure but if she went away, to some distant school, into an entirely new life, her thoughts would be diverted."

Eli Bolton almost laughed as he regarded his wife, with eyes that never looked at her except fondly, and replied,

"Perhaps thee remembers that thee had notions also, before we were married, and before thee became a member of Meeting. I think Ruth comes honestly by certain tendencies which thee has hidden under the Friend's dress."

Margaret could not say no to this, and while she paused, it was evident that memory was busy with suggestions to shake her present opinions.

"Why not let Ruth try the study for a time," suggested Eli; "there is a fair beginning of a Woman's Medical College in the city. Quite likely she will soon find that she needs first a more general culture, and fall, in with thy wish that she should see more of the world at some large school."

There really seemed to be nothing else to be done, and Margaret consented at length without approving. And it was agreed that Ruth, in order to spare her fatigue, should take lodgings with friends near the college and make a trial in the pursuit of that science to which we all owe our lives, and sometimes as by a miracle of escape.

That day Mr. Bolton brought home a stranger to dinner, Mr. Bigler of the great firm of Pennybacker, Bigler & Small, railroad contractors. He was always bringing home somebody, who had a scheme; to build a road, or open a mine, or plant a swamp with cane to grow paper-stock, or found a hospital, or invest in a patent shad-bone separator, or start a college somewhere on the frontier, contiguous to a land speculation.

The Bolton house was a sort of hotel for this kind of people. They were always coming. Ruth had known them from childhood, and she used to say that her father attracted them as naturally as a sugar hogshead does flies. Ruth had an idea that a large portion of the world lived by getting the rest of the world into schemes. Mr. Bolton never could say "no" to any of them, not even, said Ruth again, to the society for stamping oyster shells with scripture texts before they were sold at retail.

Mr. Bigler's plan this time, about which he talked loudly, with his mouth full, all dinner time, was the building of the Tunkhannock, Rattlesnake and Youngwomans-town railroad, which would not only be a great highway to the west, but would open to market inexhaustible coal-fields and untold millions of lumber. The plan of operations was very simple.

"We'll buy the lands," explained he, "on long time, backed by the notes of good men; and then mortgage them for money enough to get the road well on. Then get the towns on the line to issue their bonds for stock, and sell their bonds for enough to complete the road, and partly stock it, especially if we mortgage each section as we complete it. We can then sell the rest of the stock on the prospect of the business of the road through an improved country, and also sell the lands at a big advance, on the strength of the road. All we want," continued Mr. Bigler in his frank manner, "is a few thousand dollars to start the surveys, and arrange things in the legislature. There is

some parties will have to be seen, who might make us trouble."

"It will take a good deal of money to start the enterprise," remarked Mr. Bolton, who knew very well what "seeing" a Pennsylvania Legislature meant, but was too polite to tell Mr. Bigler what he thought of him, while he was his guest; "what security would one have for it?"

Mr. Bigler smiled a hard kind of smile, and said, "You'd be inside, Mr. Bolton, and you'd have the first chance in the deal."

This was rather unintelligible to Ruth, who was nevertheless somewhat amused by the study of a type of character she had seen before. At length she interrupted the conversation by asking,

"You'd sell the stock, I suppose, Mr. Bigler, to anybody who was attracted by the prospectus?"

"O, certainly, serve all alike," said Mr. Bigler, now noticing Ruth for the first time, and a little puzzled by the serene, intelligent face that was turned towards him.

"Well, what would become of the poor people who had been led to put their little money into the speculation, when you got out of it and left it half way?"

It would be no more true to say of Mr. Bigler that he was or could be embarrassed, than to say that a brass counterfeit dollar-piece would change color when refused; the question annoyed him a little, in Mr. Bolton's presence.



"Why, yes, Miss, of course, in a great enterprise for the benefit of the community there will little things occur, which, which—and, of course, the poor ought to be looked to; I tell my wife, that the poor must be looked to; if you can tell who are poor—there's so many impostors. And then, there's so many poor in the legislature to be looked after," said the contractor with a sort of a chuckle, "isn't that so, Mr. Bolton?"

Eli Bolton replied that he never had much to do with the legislature.

"Yes," continued this public benefactor, "an uncommon poor lot this year, uncommon. Consequently an expensive lot. The fact is, Mr. Bolton, that the price is raised so high on United States Senator now, that it affects the whole market; you can't get any public improvement through on reasonable terms. Simony is what I call it, Simony," repeated Mr. Bigler, as if he had said a good thing.

Mr. Bigler went on and gave some very interesting details of the intimate connection between railroads and politics, and thoroughly entertained himself all dinner time, and as much disgusted Ruth, who asked no more questions, and her father who replied in monosyllables:

"I wish," said Ruth to her father, after the guest had gone, "that you wouldn't bring home any more such horrid men. Do all men who wear big diamond breast-pins, flourish their knives at table, and use bad grammar, and

cheat?"

"O, child, thee mustn't be too observing. Mr. Bigler is one of the most important men in the state; nobody has more influence at Harrisburg. I don't like him any more than thee does, but I'd better lend him a little money than to have his ill will."

"Father, I think thee'd better have his ill-will than his company. Is it true that he gave money to help build the pretty little church of St. James the Less, and that he is, one of the vestrymen?"

"Yes. He is not such a bad fellow. One of the men in Third street asked him the other day, whether his was a high church or a low church? Bigler said he didn't know; he'd been in it once, and he could touch the ceiling in the side aisle with his hand."

"I think he's just horrid," was Ruth's final summary of him, after the manner of the swift judgment of women, with no consideration of the extenuating circumstances. Mr. Bigler had no idea that he had not made a good impression on the whole family; he certainly intended to be agreeable. Margaret agreed with her daughter, and though she never said anything to such people, she was grateful to Ruth for sticking at least one pin into him.

Such was the serenity of the Bolton household that a stranger in it would never have suspected there was any opposition to Ruth's going to the Medical School. And she went quietly to take her residence in town, and began her attendance of the lectures, as if it were the most natural thing in the world. She did not heed, if she heard, the busy and wondering gossip of relations and acquaintances, gossip that has no less currency among the Friends than elsewhere because it is whispered slyly and creeps about in an undertone.

Ruth was absorbed, and for the first time in her life thoroughly happy; happy in the freedom of her life, and in the keen enjoyment of the investigation that broadened its field day by day. She was in high spirits when she came home to spend First Days; the house was full of her gaiety and her merry laugh, and the children wished that Ruth would never go away again. But her mother noticed, with a little anxiety, the sometimes flushed face, and the sign of an eager spirit in the kindling eyes, and, as well, the serious air of determination and endurance in her face at unguarded moments.

The college was a small one and it sustained itself not without difficulty in this city, which is so conservative, and is yet the origin of so many radical movements. There were not more than a dozen attendants on the lectures all together, so that the enterprise had the air of an experiment, and the fascination of pioneering for those engaged in it. There was one woman physician driving about town in her carriage, attacking the most violent diseases in all quarters with persistent courage, like a modern Bellona in her war chariot, who was popularly supposed to gather in fees to the amount ten to twenty thousand dollars a year. Perhaps some of these students looked forward to the near day when they would support such a practice and a husband besides, but it is unknown that any of them ever went further than practice in hospitals and in their own nurseries, and it is feared that some of them were quite as ready as their sisters, in emergencies, to "call a man."

If Ruth had any exaggerated expectations of a professional life, she kept them to herself, and was known to her fellows of the class simply as a cheerful, sincere student, eager in her investigations, and never impatient at anything, except an insinuation that women had not as much mental capacity for science as men.

"They really say," said one young Quaker sprig to another youth of his age, "that Ruth Bolton is really going to be a saw-bones, attends lectures, cuts up bodies, and all that. She's cool enough for a surgeon, anyway." He spoke feelingly, for he had very likely been weighed in Ruth's calm eyes sometime, and thoroughly scared by the little laugh that accompanied a puzzling reply to one of his conversational nothings. Such young gentlemen, at this time, did not come very distinctly into Ruth's horizon, except as amusing circumstances.

About the details of her student life, Ruth said very little to her friends, but they had reason to know, afterwards, that it required all her nerve and the almost complete exhaustion of her physical strength, to carry her through. She began her anatomical practice upon detached portions of the human frame, which were brought into the demonstrating room—dissecting the eye, the ear, and a small tangle of muscles and nerves—an occupation which had not much more savor of death in it than the analysis of a portion of a plant out of which the life went when it was plucked up by the roots. Custom inures the most sensitive persons to that which is at first most repellent; and in the late war we saw the most delicate women, who could not at home endure the sight of blood, become so used to scenes of carnage, that they walked the hospitals and the margins of battle-fields, amid the poor remnants of torn humanity, with as perfect self-possession as if they were strolling in a flower garden.



It happened that Ruth was one evening deep in a line of investigation which she could not finish or understand without demonstration, and so eager was she in it, that it seemed as if she could not wait till the next day. She, therefore, persuaded a fellow student, who was reading that evening with her, to go down to the dissecting room of the college, and ascertain what they wanted to know by an hour's work there. Perhaps, also, Ruth wanted to test her own nerve, and to see whether the power of association was stronger in her mind than her own will.

The janitor of the shabby and comfortless old building admitted the girls, not without suspicion, and gave them lighted candles, which they would need, without other remark than "there's a new one, Miss," as the girls went up the broad stairs.

They climbed to the third story, and paused before a door, which they unlocked, and which admitted them into a long apartment, with a row of windows on one side and one at the end. The room was without light, save from the stars and the candles the girls carried, which revealed to them dimly two long and several small tables, a few benches and chairs, a couple of skeletons hanging on the wall, a sink, and cloth-covered heaps of something upon the tables here and there.

The windows were open, and the cool night wind came in strong enough to flutter a white covering now and then, and to shake the loose casements. But all the sweet odors of the night could not take from the room a faint suggestion of mortality.

The young ladies paused a moment. The room itself was familiar enough, but night makes almost any chamber eerie, and especially such a room of detention as this where the mortal parts of the unburied might—almost be

supposed to be, visited, on the sighing night winds, by the wandering spirits of their late tenants.

Opposite and at some distance across the roofs of lower buildings, the girls saw a tall edifice, the long upper story of which seemed to be a dancing hall. The windows of that were also open, and through them they heard the scream of the jiggered and tortured violin, and the pump, pump of the oboe, and saw the moving shapes of men and women in quick transition, and heard the prompter's drawl.

"I wonder," said Ruth, "what the girls dancing there would think if they saw us, or knew that there was such a room as this so near them."

She did not speak very loud, and, perhaps unconsciously, the girls drew near to each other as they approached the long table in the centre of the room. A straight object lay upon it, covered with a sheet. This was doubtless "the new one" of which the janitor spoke. Ruth advanced, and with a not very steady hand lifted the white covering from the upper part of the figure and turned it down. Both the girls started. It was a negro. The black face seemed to defy the pallor of death, and asserted an ugly life-likeness that was frightful.



Ruth was as pale as the white sheet, and her comrade whispered, "Come away, Ruth, it is awful."

Perhaps it was the wavering light of the candles, perhaps it was only the agony from a death of pain, but the repulsive black face seemed to wear a scowl that said, "Haven't you yet done with the outcast, persecuted black man, but you must now haul him from his grave, and send even your women to dismember his body?"

Who is this dead man, one of thousands who died yesterday, and will be dust anon, to protest that science shall not turn his worthless carcass to some account?

Ruth could have had no such thought, for with a pity in her sweet face, that for the moment overcame fear and disgust, she reverently replaced the covering, and went away to her own table, as her companion did to hers. And there for an hour they worked at their several problems, without speaking, but not without an awe of the presence there, "the new one," and not without an awful sense of life itself, as they heard the pulsations of the music and the light laughter from the dancing-hall.

When, at length, they went away, and locked the dreadful room behind them, and came out into the street, where people were passing, they, for the first time, realized, in the relief they felt, what a nervous strain they had been under.

CHAPTER XVI.

While Ruth was thus absorbed in her new occupation, and the spring was wearing away, Philip and his friends were still detained at the Southern Hotel. The great contractors had concluded their business with the state and railroad officials and with the lesser contractors, and departed for the East. But the serious illness of one of the engineers kept Philip and Henry in the city and occupied in alternate watchings.

Philip wrote to Ruth of the new acquaintance they had made, Col. Sellers, an enthusiastic and hospitable gentleman, very much interested in the development of the country, and in their success. They had not had an opportunity to visit at his place "up in the country" yet, but the Colonel often dined with them, and in confidence, confided to them his projects, and seemed to take a great liking to them, especially to his friend Harry. It was true that he never seemed to have ready money, but he was engaged in very large operations.

The correspondence was not very brisk between these two young persons, so differently occupied; for though Philip wrote long letters, he got brief ones in reply, full of sharp little observations however, such as one concerning Col. Sellers, namely, that such men dined at their house every week.

Ruth's proposed occupation astonished Philip immensely, but while he argued it and discussed it, he did not dare hint to her his fear that it would interfere with his most cherished plans. He too sincerely respected Ruth's judgment to make any protest, however, and he would have defended her course against the world.

This enforced waiting at St. Louis was very irksome to Philip. His money was running away, for one thing, and he longed to get into the field, and see for himself what chance there was for a fortune or even an occupation. The contractors had given the young men leave to join the engineer corps as soon as they could, but otherwise had made no provision for them, and in fact had left them with only the most indefinite expectations of something large in the future.

Harry was entirely happy; in his circumstances. He very soon knew everybody, from the governor of the state down to the waiters at the hotel. He had the Wall street slang at his tongue's end; he always talked like a capitalist, and entered with enthusiasm into all the land and railway schemes with which the air was thick.

Col. Sellers and Harry talked together by the hour and by the day. Harry informed his new friend that he was going out with the engineer corps of the Salt Lick Pacific Extension, but that wasn't his real business.

"I'm to have, with another party," said Harry, "a big contract in the road, as soon as it is let; and, meantime, I'm with the engineers to spy out the best land and the depot sites."

"It's everything," suggested the Colonel, "in knowing where to invest. I've known people throwaway their money because they were too consequential to take Sellers' advice. Others, again, have made their pile on taking it. I've looked over the ground; I've been studying it for twenty years. You can't put your finger on a spot in the map of Missouri that I don't know as if I'd made it. When you want to place anything," continued the Colonel, confidently, "just let Beriah Sellers know. That's all."

"Oh, I haven't got much in ready money I can lay my hands on now, but if a fellow could do anything with fifteen or twenty thousand dollars, as a beginning, I shall draw for that when I see the right opening."

"Well, that's something, that's something, fifteen or twenty thousand dollars, say twenty—as an advance," said the Colonel reflectively, as if turning over his mind for a project that could be entered on with such a trifling sum.



"I'll tell you what it is—but only to you Mr. Brierly, only to you, mind; I've got a little project that I've been keeping. It looks small, looks small on paper, but it's got a big future. What should you say, sir, to a city, built up like the rod of Aladdin had touched it, built up in two years, where now you wouldn't expect it any more than you'd expect a light-house on the top of Pilot Knob? and you could own the land! It can be done, sir. It can be done!"

The Colonel hitched up his chair close to Harry, laid his hand on his knee, and, first looking about him, said in a low voice, "The Salt Lick Pacific Extension is going to run through Stone's Landing! The Almighty never laid out a cleaner piece of level prairie for a city; and it's the natural center of all that region of hemp and tobacco."

"What makes you think the road will go there? It's twenty miles, on the map, off the straight line of the road?"

"You can't tell what is the straight line till the engineers have been over it. Between us, I have talked with Jeff Thompson, the division engineer. He understands the wants of Stone's Landing, and the claims of the inhabitants—who are to be there. Jeff says that a railroad is for—the accommodation of the people and not for the benefit of gophers; and if, he don't run this to Stone's Landing he'll be damned! You ought to know Jeff; he's one of the most enthusiastic engineers in this western country, and one of the best fellows that ever looked through the bottom of a glass."

The recommendation was not undeserved. There was nothing that Jeff wouldn't do, to accommodate a friend, from sharing his last dollar with him, to winging him in a duel. When he understood from Col. Sellers. how the land lay at Stone's Landing, he cordially shook hands with that gentleman, asked him to drink, and fairly roared out, "Why, God bless my soul, Colonel, a word from one Virginia gentleman to another is 'nuff ced.' There's Stone's Landing been waiting for a railroad more than four thousand years, and damme if she shan't have it."

Philip had not so much faith as Harry in Stone's Landing, when the latter opened the project to him, but Harry talked about it as if he already owned that incipient city.

Harry thoroughly believed in all his projects and inventions, and lived day by day in their golden atmosphere. Everybody liked the young fellow, for how could they help liking one of such engaging manners and large fortune? The waiters at the hotel would do more for him than for any other guest, and he made a great many

acquaintances among the people of St. Louis, who liked his sensible and liberal views about the development of the western country, and about St. Louis. He said it ought to be the national capital. Harry made partial arrangements with several of the merchants for furnishing supplies for his contract on the Salt Lick Pacific Extension; consulted the maps with the engineers, and went over the profiles with the contractors, figuring out estimates for bids. He was exceedingly busy with those things when he was not at the bedside of his sick acquaintance, or arranging the details of his speculation with Col. Sellers.

Meantime the days went along and the weeks, and the money in Harry's pocket got lower and lower. He was just as liberal with what he had as before, indeed it was his nature to be free with his money or with that of others, and he could lend or spend a dollar with an air that made it seem like ten. At length, at the end of one week, when his hotel bill was presented, Harry found not a cent in his pocket to meet it. He carelessly remarked to the landlord that he was not that day in funds, but he would draw on New York, and he sat down and wrote to the contractors in that city a glowing letter about the prospects of the road, and asked them to advance a hundred or two, until he got at work. No reply came. He wrote again, in an unoffended business like tone, suggesting that he had better draw at three days. A short answer came to this, simply saying that money was very tight in Wall street just then, and that he had better join the engineer corps as soon as he could.

But the bill had to be paid, and Harry took it to Philip, and asked him if he thought he hadn't better draw on his uncle. Philip had not much faith in Harry's power of "drawing," and told him that he would pay the bill himself. Whereupon Harry dismissed the matter then and thereafter from his thoughts, and, like a light-hearted good fellow as he was, gave himself no more trouble about his board-bills. Philip paid them, swollen as they were with a monstrous list of extras; but he seriously counted the diminishing bulk of his own hoard, which was all the money he had in the world. Had he not tacitly agreed to share with Harry to the last in this adventure, and would not the generous fellow divide; with him if he, Philip, were in want and Harry had anything?

The fever at length got tired of tormenting the stout young engineer, who lay sick at the hotel, and left him, very thin, a little sallow but an "acclimated" man. Everybody said he was "acclimated" now, and said it cheerfully. What it is to be acclimated to western fevers no two persons exactly agree.

Some say it is a sort of vaccination that renders death by some malignant type of fever less probable. Some regard it as a sort of initiation, like that into the Odd Fellows, which renders one liable to his regular dues thereafter. Others consider it merely the acquisition of a habit of taking every morning before breakfast a dose of bitters, composed of whiskey and assafoetida, out of the acclimation jug.

Jeff Thompson afterwards told Philip that he once asked Senator Atchison, then acting Vice-President: of the United States, about the possibility of acclimation; he thought the opinion of the second officer of our great government would be, valuable on this point. They were sitting together on a bench before a country tavern, in the free converse permitted by our democratic habits.

"I suppose, Senator, that you have become acclimated to this country?"



Fortunata Dancing

"Well," said the Vice-President, crossing his legs, pulling his wide-awake down over his forehead, causing a passing chicken to hop quickly one side by the accuracy of his aim, and speaking with senatorial deliberation, "I think I have. I've been here twenty-five years, and dash, dash my dash to dash, if I haven't entertained twenty-five separate and distinct earthquakes, one a year. The niggro is the only person who can stand the fever and ague of this region."

The convalescence of the engineer was the signal for breaking up quarters at St. Louis, and the young fortune-hunters started up the river in good spirits. It was only the second time either of them had been upon a Mississippi steamboat, and nearly everything they saw had the charm of novelty. Col. Sellers was at the landing to bid thorn good-bye.



"I shall send you up that basket of champagne by the next boat; no, no; no thanks; you'll find it not bad in camp," he cried out as the plank was hauled in. "My respects to Thompson. Tell him to sight for Stone's. Let me know, Mr. Brierly, when you are ready to locate; I'll come over from Hawkeye. Goodbye."

And the last the young fellows saw of the Colonel, he was waving his hat, and beaming prosperity and good luck.

The voyage was delightful, and was not long enough to become monotonous. The travelers scarcely had time indeed to get accustomed to the splendors of the great saloon where the tables were spread for meals, a marvel of paint and gilding, its ceiling hung with fancifully cut tissue-paper of many colors, festooned and arranged in endless patterns. The whole was more beautiful than a barber's shop. The printed bill of fare at dinner was longer and more varied, the proprietors justly boasted, than that of any hotel in New York. It must have been the work of an author of talent and imagination, and it surely was not his fault if the dinner itself was to a certain extent a delusion, and if the guests got something that tasted pretty much the same whatever dish they ordered; nor was it his fault if a general flavor of rose in all the dessert dishes suggested that they had passed through the barber's saloon on their way from the kitchen.

The travelers landed at a little settlement on the left bank, and at once took horses for the camp in the interior, carrying their clothes and blankets strapped behind the saddles. Harry was dressed as we have seen him once before, and his long and shining boots attracted not a little the attention of the few persons they met on the road, and especially of the bright faced wenches who lightly stepped along the highway, picturesque in their colored kerchiefs, carrying light baskets, or riding upon mules and balancing before them a heavier load.

Harry sang fragments of operas and talked about their fortune. Philip even was excited by the sense of freedom and adventure, and the beauty of the landscape. The prairie, with its new grass and unending acres of brilliant

The Gilded Age, Illustrated, Volume 2.

flowers—chiefly the innumerable varieties of phlox—bore the look of years of cultivation, and the occasional open groves of white oaks gave it a park-like appearance. It was hardly unreasonable to expect to see at any moment, the gables and square windows of an Elizabethan mansion in one of the well kept groves.

Towards sunset of the third day, when the young gentlemen thought they ought to be near the town of Magnolia, near which they had been directed to find the engineers' camp, they descried a log house and drew up before it to enquire the way. Half the building was store, and half was dwelling house. At the door of the latter stood a regress with a bright turban on her head, to whom Philip called,

"Can you tell me, auntie, how far it is to the town of Magnolia?"

"Why, bress you chile," laughed the woman, "you's dere now."



It was true. This log horse was the compactly built town, and all creation was its suburbs. The engineers' camp was only two or three miles distant.

"You's boun' to find it," directed auntie, "if you don't keah nuffin 'bout de road, and go fo' de sun-down."

A brisk gallop brought the riders in sight of the twinkling light of the camp, just as the stars came out. It lay in a little hollow, where a small stream ran through a sparse grove of young white oaks. A half dozen tents were pitched under the trees, horses and oxen were corraled at a little distance, and a group of men sat on camp stools or lay on blankets about a bright fire. The twang of a banjo became audible as they drew nearer, and they saw a couple of negroes, from some neighboring plantation, "breaking down" a juba in approved style, amid the "hi, hi's" of the spectators.

Mr. Jeff Thompson, for it was the camp of this redoubtable engineer, gave the travelers a hearty welcome, offered them ground room in his own tent, ordered supper, and set out a small jug, a drop from which he declared necessary on account of the chill of the evening.

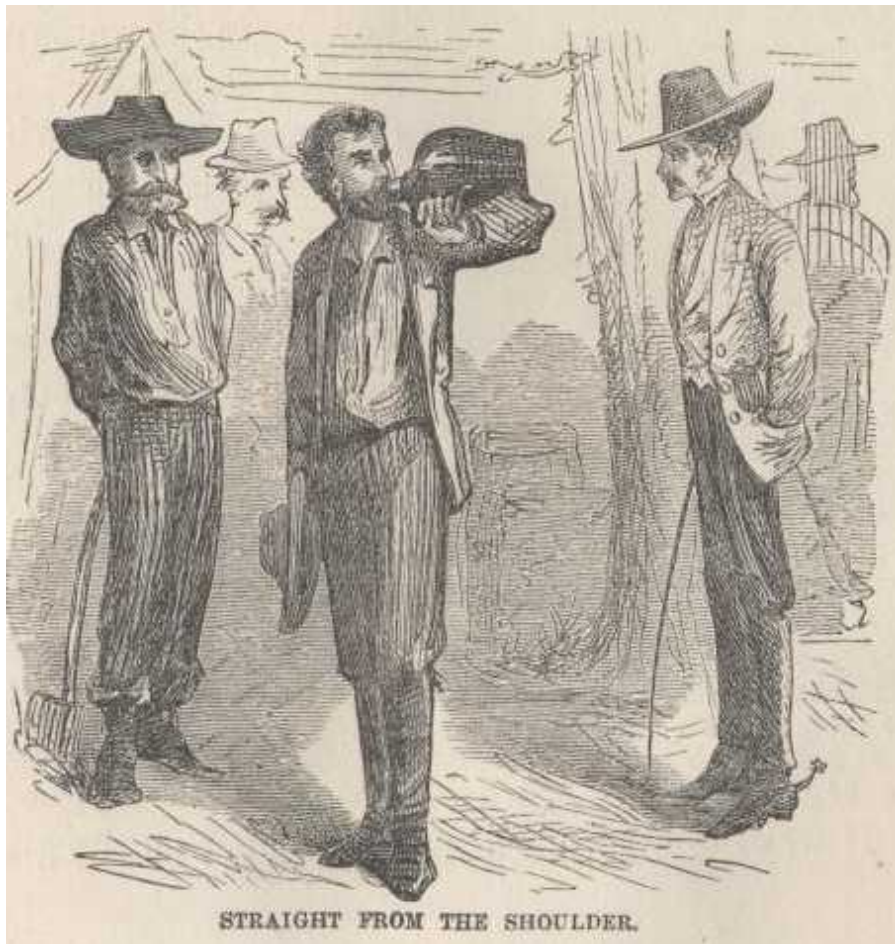

"I never saw an Eastern man," said Jeff, "who knew how to drink from a jug with one hand. It's as easy as

lying. So." He grasped the handle with the right hand, threw the jug back upon his arm, and applied his lips to the nozzle. It was an act as graceful as it was simple. "Besides," said Mr. Thompson, setting it down, "it puts every man on his honor as to quantity."

Early to turn in was the rule of the camp, and by nine o'clock everybody was under his blanket, except Jeff himself, who worked awhile at his table over his field-book, and then arose, stepped outside the tent door and sang, in a strong and not unmelodious tenor, the Star Spangled Banner from beginning to end. It proved to be his nightly practice to let off the unexpended seam of his conversational powers, in the words of this stirring song.

It was a long time before Philip got to sleep. He saw the fire light, he saw the clear stars through the tree-tops, he heard the gurgle of the stream, the stamp of the horses, the occasional barking of the dog which followed the cook's wagon, the hooting of an owl; and when these failed he saw Jeff, standing on a battlement, mid the rocket's red glare, and heard him sing, "Oh, say, can you see?", It was the first time he had ever slept on the ground.



CHAPTER XVII.

——"We have view'd it,
And measur'd it within all, by the scale
The richest tract of land, love, in the kingdom!
There will be made seventeen or eighteen millions,
Or more, as't may be handled!

The Devil is an Ass.

Nobody dressed more like an engineer than Mr. Henry Brierly. The completeness of his appointments was the envy of the corps, and the gay fellow himself was the admiration of the camp servants, axemen, teamsters and cooks.

"I reckon you didn't git them boots no wher's this side o' Sent Louis?" queried the tall Missouri youth who acted as commissary's assistant.

"No, New York."

"Yas, I've heern o' New York," continued the butternut lad, attentively studying each item of Harry's dress, and endeavoring to cover his design with interesting conversation. "'N there's Massachusetts.",

"It's not far off."

"I've heern Massachusetts was a——of a place. Les, see, what state's Massachusetts in?"

"Massachusetts," kindly replied Harry, "is in the state of Boston."

"Abolish'n wan't it? They must a cost right smart," referring to the boots.

Harry shouldered his rod and went to the field, tramped over the prairie by day, and figured up results at night, with the utmost cheerfulness and industry, and plotted the line on the profile paper, without, however, the least idea of engineering practical or theoretical. Perhaps there was not a great deal of scientific knowledge in the entire corps, nor was very much needed. They were making, what is called a preliminary survey, and the chief object of a preliminary survey was to get up an excitement about the road, to interest every town in that part of the state in it, under the belief that the road would run through it, and to get the aid of every planter upon the prospect that a station would be on his land.

Mr. Jeff Thompson was the most popular engineer who could be found for this work. He did not bother himself much about details or practicabilities of location, but ran merrily along, sighting from the top of one divide to the top of another, and striking "plumb" every town site and big plantation within twenty or thirty miles of his route. In his own language he "just went booming."

This course gave Harry an opportunity, as he said, to learn the practical details of engineering, and it gave Philip a chance to see the country, and to judge for himself what prospect of a fortune it offered. Both he and Harry got the "refusal" of more than one plantation as they went along, and wrote urgent letters to their eastern correspondents, upon the beauty of the land and the certainty that it would quadruple in value as soon as the road was finally located. It seemed strange to them that capitalists did not flock out there and secure this land.

They had not been in the field over two weeks when Harry wrote to his friend Col. Sellers that he'd better be on the move, for the line was certain to go to Stone's Landing. Any one who looked at the line on the map, as it was laid down from day to day, would have been uncertain which way it was going; but Jeff had declared that in his judgment the only practicable route from the point they then stood on was to follow the divide to Stone's Landing, and it was generally understood that that town would be the next one hit.

"We'll make it, boys," said the chief, "if we have to go in a balloon."



And make it they did In less than a week, this indomitable engineer had carried his moving caravan over slues and branches, across bottoms and along divides, and pitched his tents in the very heart of the city of Stone's Landing.

"Well, I'll be dashed," was heard the cheery voice of Mr. Thompson, as he stepped outside the tent door at sunrise next morning. "If this don't get me. I say, yon, Grayson, get out your sighting iron and see if you can find old Sellers' town. Blame me if we wouldn't have run plumb by it if twilight had held on a little longer. Oh! Sterling, Brierly, get up and see the city. There's a steamboat just coming round the bend." And Jeff roared with laughter. "The mayor'll be round here to breakfast."



The fellows turned out of the tents, rubbing their eyes, and stared about them. They were camped on the second bench of the narrow bottom of a crooked, sluggish stream, that was some five rods wide in the present good stage of water. Before them were a dozen log cabins, with stick and mud chimneys, irregularly disposed on either side of a not very well defined road, which did not seem to know its own mind exactly, and, after straggling through the town, wandered off over the rolling prairie in an uncertain way, as if it had started for nowhere and was quite likely to reach its destination. Just as it left the town, however, it was cheered and assisted by a guide-board, upon which was the legend "10 Mils to Hawkeye."

The road had never been made except by the travel over it, and at this season—the rainy June—it was a way of ruts cut in the black soil, and of fathomless mud-holes. In the principal street of the city, it had received more attention; for hogs; great and small, rooted about in it and wallowed in it, turning the street into a liquid quagmire which could only be crossed on pieces of plank thrown here and there.

About the chief cabin, which was the store and grocery of this mart of trade, the mud was more liquid than elsewhere, and the rude platform in front of it and the dry-goods boxes mounted thereon were places of refuge for all the loafers of the place. Down by the stream was a dilapidated building which served for a hemp warehouse, and a shaky wharf extended out from it, into the water. In fact a flat-boat was there moored by it, its setting poles lying across the gunwales. Above the town the stream was crossed by a crazy wooden bridge, the supports of which leaned all ways in the soggy soil; the absence of a plank here and there in the flooring made the crossing of the bridge faster than a walk an offense not necessary to be prohibited by law.

"This, gentlemen," said Jeff, "is Columbus River, alias Goose Run. If it was widened, and deepened, and straightened, and made, long enough, it would be one of the finest rivers in the western country."

As the sun rose and sent his level beams along the stream, the thin stratum of mist, or malaria, rose also and dispersed, but the light was not able to enliven the dull water nor give any hint of its apparently fathomless depth. Venerable mud-turtles crawled up and roosted upon the old logs in the stream, their backs glistening in the sun,

the first inhabitants of the metropolis to begin the active business of the day.



It was not long, however, before smoke began to issue from the city chimnies; and before the engineers, had finished their breakfast they were the object of the curious inspection of six or eight boys and men, who lounged into the camp and gazed about them with languid interest, their hands in their pockets every one.

"Good morning; gentlemen," called out the chief engineer, from the table.

"Good mawning," drawled out the spokesman of the party. "I allow thish— yers the railroad, I heern it was a—comin'."

"Yes, this is the railroad; all but the rails and the ironhorse."

"I reckon you kin git all the rails you want oaten my white oak timber over, thar," replied the first speaker, who appeared to be a man of property and willing to strike up a trade.

"You'll have to negotiate with the contractors about the rails, sir," said Jeff; "here's Mr. Brierly, I've no doubt would like to buy your rails when the time comes."

"O," said the man, "I thought maybe you'd fetch the whole bilin along with you. But if you want rails, I've got em, haint I Eph."

"Heaps," said Eph, without taking his eyes off the group at the table.

"Well," said Mr. Thompson, rising from his seat and moving towards his tent, "the railroad has come to Stone's Landing, sure; I move we take a drink on it all round."

The proposal met with universal favor. Jeff gave prosperity to Stone's Landing and navigation to Goose Run, and the toast was washed down with gusto, in the simple fluid of corn; and with the return compliment that a rail road was a good thing, and that Jeff Thompson was no slouch.

About ten o'clock a horse and wagon was descried making a slow approach to the camp over the prairie. As it drew near, the wagon was seen to contain a portly gentleman, who hitched impatiently forward on his seat, shook the reins and gently touched up his horse, in the vain attempt to communicate his own energy to that dull beast, and looked eagerly at the tents. When the conveyance at length drew up to Mr. Thompson's door, the gentleman descended with great deliberation, straightened himself up, rubbed his hands, and beaming satisfaction from every

part of his radiant frame, advanced to the group that was gathered to welcome him, and which had saluted him by name as soon as he came within hearing.

"Welcome to Napoleon, gentlemen, welcome. I am proud to see you here Mr. Thompson. You are, looking well Mr. Sterling. This is the country, sir. Right glad to see you Mr. Brierly. You got that basket of champagne? No? Those blasted river thieves! I'll never send anything more by 'em. The best brand, Roederer. The last I had in my cellar, from a lot sent me by Sir George Gore—took him out on a buffalo hunt, when he visited our, country. Is always sending me some trifle. You haven't looked about any yet, gentlemen? It's in the rough yet, in the rough. Those buildings will all have to come down. That's the place for the public square, Court House, hotels, churches, jail—all that sort of thing. About where we stand, the deepo. How does that strike your engineering eye, Mr. Thompson? Down yonder the business streets, running to the wharves. The University up there, on rising ground, sightly place, see the river for miles. That's Columbus river, only forty-nine miles to the Missouri. You see what it is, placid, steady, no current to interfere with navigation, wants widening in places and dredging, dredge out the harbor and raise a levee in front of the town; made by nature on purpose for a mart. Look at all this country, not another building within ten miles, no other navigable stream, lay of the land points right here; hemp, tobacco, corn, must come here. The railroad will do it, Napoleon won't know itself in a year."

"Don't now evidently," said Philip aside to Harry. "Have you breakfasted Colonel?"

"Hastily. Cup of coffee. Can't trust any coffee I don't import myself. But I put up a basket of provisions,—wife would put in a few delicacies, women always will, and a half dozen of that Burgundy, I was telling you of Mr. Briefly. By the way, you never got to dine with me." And the Colonel strode away to the wagon and looked under the seat for the basket.



Apparently it was not there. For the Colonel raised up the flap, looked in front and behind, and then exclaimed, "Confound it. That comes of not doing a thing yourself. I trusted to the women folks to set that basket in the wagon, and it ain't there."

The camp cook speedily prepared a savory breakfast for the Colonel, broiled chicken, eggs, corn-bread, and coffee, to which he did ample justice, and topped off with a drop of Old Bourbon, from Mr. Thompson's private store, a brand which he said he knew well, he should think it came from his own sideboard.

While the engineer corps went to the field, to run back a couple of miles and ascertain, approximately, if a road could ever get down to the Landing, and to sight ahead across the Run, and see if it could ever get out again, Col. Sellers and Harry sat down and began to roughly map out the city of Napoleon on a large piece of drawing paper.

"I've got the refusal of a mile square here," said the Colonel, "in our names, for a year, with a quarter interest reserved for the four owners."

They laid out the town liberally, not lacking room, leaving space for the railroad to come in, and for the river as it was to be when improved.

The engineers reported that the railroad could come in, by taking a little sweep and crossing the stream on a high bridge, but the grades would be steep. Col. Sellers said he didn't care so much about the grades, if the road could only be made to reach the elevators on the river. The next day Mr. Thompson made a hasty survey of the stream for a mile or two, so that the Colonel and Harry were enabled to show on their map how nobly that would accommodate the city. Jeff took a little writing from the Colonel and Harry for a prospective share but Philip declined to join in, saying that he had no money, and didn't want to make engagements he couldn't fulfill.

The next morning the camp moved on, followed till it was out of sight by the listless eyes of the group in front of the store, one of whom remarked that, "he'd be doggoned if he ever expected to see that railroad any mo'."

Harry went with the Colonel to Hawkeye to complete their arrangements, a part of which was the preparation of a petition to congress for the improvement of the navigation of Columbus River.

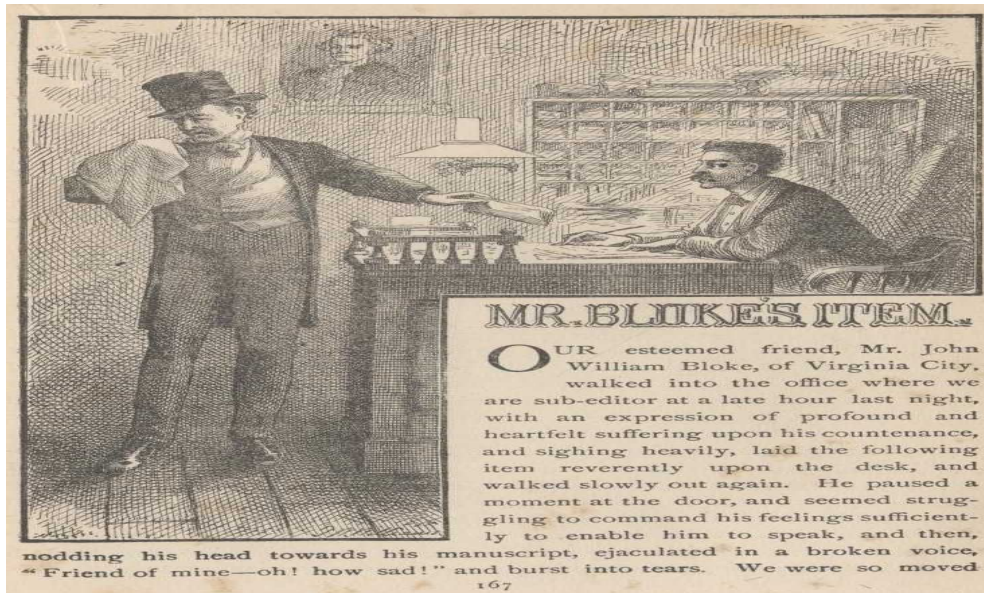

CHAPTER XVIII.

Eight years have passed since the death of Mr. Hawkins. Eight years are not many in the life of a nation or the history of a state, but they maybe years of destiny that shall fix the current of the century following. Such years were those that followed the little scrimmage on Lexington Common. Such years were those that followed the double-shotted demand for the surrender of Fort Sumter. History is never done with inquiring of these years, and summoning witnesses about them, and trying to understand their significance.

The eight years in America from 1860 to 1868 uprooted institutions that were centuries old, changed the politics of a people, transformed the social life of half the country, and wrought so profoundly upon the entire national character that the influence cannot be measured short of two or three generations.

As we are accustomed to interpret the economy of providence, the life of the individual is as nothing to that of the nation or the race; but who can say, in the broader view and the more intelligent weight of values, that the life of one man is not more than that of a nationality, and that there is not a tribunal where the tragedy of one human soul shall not seem more significant than the overturning of any human institution whatever?

When one thinks of the tremendous forces of the upper and the nether world which play for the mastery of the soul of a woman during the few years in which she passes from plastic girlhood to the ripe maturity of womanhood, he may well stand in awe before the momentous drama.

What capacities she has of purity, tenderness, goodness; what capacities of vileness, bitterness and evil. Nature must needs be lavish with the mother and creator of men, and centre in her all the possibilities of life. And a few critical years can decide whether her life is to be full of sweetness and light, whether she is to be the vestal of a holy temple, or whether she will be the fallen priestess of a desecrated shrine. There are women, it is true, who seem to be capable neither of rising much nor of falling much, and whom a conventional life saves from any special development of character.

But Laura was not one of them. She had the fatal gift of beauty, and that more fatal gift which does not always accompany mere beauty, the power of fascination, a power that may, indeed, exist without beauty. She had will, and pride and courage and ambition, and she was left to be very much her own guide at the age when romance comes to the aid of passion, and when the awakening powers of her vigorous mind had little object on which to discipline themselves.

The tremendous conflict that was fought in this girl's soul none of those about her knew, and very few knew that her life had in it anything unusual or romantic or strange.

Those were troublous days in Hawkeye as well as in most other Missouri towns, days of confusion, when between Unionist and Confederate occupations, sudden maraudings and bush-whackings and raids, individuals escaped observation or comment in actions that would have filled the town with scandal in quiet times.

Fortunately we only need to deal with Laura's life at this period historically, and look back upon such portions of it as will serve to reveal the woman as she was at the time of the arrival of Mr. Harry Brierly in Hawkeye.

The Hawkins family were settled there, and had a hard enough struggle with poverty and the necessity of keeping up appearances in accord with their own family pride and the large expectations they secretly cherished of a fortune in the Knobs of East Tennessee. How pinched they were perhaps no one knew but Clay, to whom they looked for almost their whole support. Washington had been in Hawkeye off and on, attracted away occasionally by some tremendous speculation, from which he invariably returned to Gen. Boswell's office as poor as he went. He was the inventor of no one knew how many useless contrivances, which were not worth patenting, and his years had been passed in dreaming and planning to no purpose; until he was now a man of about thirty, without a profession or a permanent occupation, a tall, brown-haired, dreamy person of the best intentions and the frailest resolution. Probably however the, eight years had been happier to him than to any others in his circle, for the time had been mostly spent in a blissful dream of the coming of enormous wealth.

He went out with a company from Hawkeye to the war, and was not wanting in courage, but he would have been a better soldier if he had been less engaged in contrivances for circumventing the enemy by strategy unknown to the books.



It happened to him to be captured in one of his self-appointed expeditions, but the federal colonel released him, after a short examination, satisfied that he could most injure the confederate forces opposed to the Unionists by returning him to his regiment. Col. Sellers was of course a prominent man during the war. He was captain of the home guards in Hawkeye, and he never left home except upon one occasion, when on the strength of a rumor, he executed a flank movement and fortified Stone's Landing, a place which no one unacquainted with the country would be likely to find.

"Gad," said the Colonel afterwards, "the Landing is the key to upper Missouri, and it is the only place the enemy never captured. If other places had been defended as well as that was, the result would have been different, sir."

The Colonel had his own theories about war as he had in other things. If everybody had stayed at home as he did, he said, the South never would have been conquered. For what would there have been to conquer? Mr. Jeff Davis was constantly writing him to take command of a corps in the confederate army, but Col. Sellers said, no, his duty was at home. And he was by no means idle. He was the inventor of the famous air torpedo, which came very near destroying the Union armies in Missouri, and the city of St. Louis itself.

His plan was to fill a torpedo with Greek fire and poisonous and deadly missiles, attach it to a balloon, and then let it sail away over the hostile camp and explode at the right moment, when the time-fuse burned out. He intended to use this invention in the capture of St. Louis, exploding his torpedoes over the city, and raining destruction upon it until the army of occupation would gladly capitulate. He was unable to procure the Greek fire, but he constructed a vicious torpedo which would have answered the purpose, but the first one prematurely exploded in his wood-house, blowing it clean away, and setting fire to his house. The neighbors helped him put

out the conflagration, but they discouraged any more experiments of that sort.

The patriotic old gentleman, however, planted so much powder and so many explosive contrivances in the roads leading into Hawkeye, and then forgot the exact spots of danger, that people were afraid to travel the highways, and used to come to town across the fields, The Colonel's motto was, "Millions for defence but not one cent for tribute."

When Laura came to Hawkeye she might have forgotten the annoyances of the gossips of Murpheysburg and have out lived the bitterness that was growing in her heart, if she had been thrown less upon herself, or if the surroundings of her life had been more congenial and helpful. But she had little society, less and less as she grew older that was congenial to her, and her mind preyed upon itself; and the mystery of her birth at once chagrined her and raised in her the most extravagant expectations. She was proud and she felt the sting of poverty. She could not but be conscious of her beauty also, and she was vain of that, and came to take a sort of delight in the exercise of her fascinations upon the rather loutish young men who came in her way and whom she despised.

There was another world opened to her—a world of books. But it was not the best world of that sort, for the small libraries she had access to in Hawkeye were decidedly miscellaneous, and largely made up of romances and fictions which fed her imagination with the most exaggerated notions of life, and showed her men and women in a very false sort of heroism. From these stories she learned what a woman of keen intellect and some culture joined to beauty and fascination of manner, might expect to accomplish in society as she read of it; and along with these ideas she imbibed other very crude ones in regard to the emancipation of woman.

There were also other books—histories, biographies of distinguished people, travels in far lands, poems, especially those of Byron, Scott and Shelley and Moore, which she eagerly absorbed, and appropriated therefrom what was to her liking. Nobody in Hawkeye had read so much or, after a fashion, studied so diligently as Laura. She passed for an accomplished girl, and no doubt thought herself one, as she was, judged by any standard near her.

During the war there came to Hawkeye a confederate officer, Col. Selby, who was stationed there for a time, in command of that district. He was a handsome, soldierly man of thirty years, a graduate of the University of Virginia, and of distinguished family, if his story might be believed, and, it was evident, a man of the world and of extensive travel and adventure.

To find in such an out of the way country place a woman like Laura was a piece of good luck upon which Col. Selby congratulated himself. He was studiously polite to her and treated her with a consideration to which she was unaccustomed. She had read of such men, but she had never seen one before, one so high-bred, so noble in sentiment, so entertaining in conversation, so engaging in manner.

It is a long story; unfortunately it is an old story, and it need not be dwelt on. Laura loved him, and believed that his love for her was as pure and deep as her own. She worshipped him and would have counted her life a little thing to give him, if he would only love her and let her feed the hunger of her heart upon him.

The passion possessed her whole being, and lifted her up, till she seemed to walk on air. It was all true, then, the romances she had read, the bliss of love she had dreamed of. Why had she never noticed before how blithesome the world was, how jocund with love; the birds sang it, the trees whispered it to her as she passed, the very flowers beneath her feet strewed the way as for a bridal march.

When the Colonel went away they were engaged to be married, as soon as he could make certain arrangements which he represented to be necessary, and quit the army. He wrote to her from Harding, a small town in the southwest corner of the state, saying that he should be held in the service longer than he had expected, but that it would not be more than a few months, then he should be at liberty to take her to Chicago where he had property, and should have business, either now or as soon as the war was over, which he thought could not last long. Meantime why should they be separated? He was established in comfortable quarters, and if she could find company and join him, they would be married, and gain so many more months of happiness.

Was woman ever prudent when she loved? Laura went to Harding, the neighbors supposed to nurse Washington who had fallen ill there. Her engagement was, of course, known in Hawkeye, and was indeed a matter of pride to her family. Mrs. Hawkins would have told the first inquirer that. Laura had gone to be married; but Laura had cautioned her; she did not want to be thought of, she said, as going in search of a husband; let the news come back after she was married.

So she traveled to Harding on the pretence we have mentioned, and was married. She was married, but

something must have happened on that very day or the next that alarmed her. Washington did not know then or after what it was, but Laura bound him not to send news of her marriage to Hawkeye yet, and to enjoin her mother not to speak of it. Whatever cruel suspicion or nameless dread this was, Laura tried bravely to put it away, and not let it cloud her happiness.

Communication that summer, as may be imagined, was neither regular nor frequent between the remote confederate camp at Harding and Hawkeye, and Laura was in a measure lost sight of—indeed, everyone had troubles enough of his own without borrowing from his neighbors.

Laura had given herself utterly to her husband, and if he had faults, if he was selfish, if he was sometimes coarse, if he was dissipated, she did not or would not see it. It was the passion of her life, the time when her whole nature went to flood tide and swept away all barriers. Was her husband ever cold or indifferent? She shut her eyes to everything but her sense of possession of her idol.

Three months passed. One morning her husband informed her that he had been ordered South, and must go within two hours.

"I can be ready," said Laura, cheerfully.

"But I can't take you. You must go back to Hawkeye."

"Can't—take—me?" Laura asked, with wonder in her eyes. "I can't live without you. You said——"

"O bother what I said,"—and the Colonel took up his sword to buckle it on, and then continued coolly, "the fact is Laura, our romance is played out."

Laura heard, but she did not comprehend. She caught his arm and cried, "George, how can you joke so cruelly? I will go any where with you. I will wait any where. I can't go back to Hawkeye."

"Well, go where you like. Perhaps," continued he with a sneer, "you would do as well to wait here, for another colonel."

Laura's brain whirled. She did not yet comprehend. "What does this mean? Where are you going?"

"It means," said the officer, in measured words, "that you haven't anything to show for a legal marriage, and that I am going to New Orleans."

"It's a lie, George, it's a lie. I am your wife. I shall go. I shall follow you to New Orleans."

"Perhaps my wife might not like it!"

Laura raised her head, her eyes flamed with fire, she tried to utter a cry, and fell senseless on the floor.



INSIDE THE TOWN.

When she came to herself the Colonel was gone. Washington Hawkins stood at her bedside. Did she come to herself? Was there anything left in her heart but hate and bitterness, a sense of an infamous wrong at the hands of the only man she had ever loved?

She returned to Hawkeye. With the exception of Washington and his mother, no one knew what had happened. The neighbors supposed that the engagement with Col. Selby had fallen through. Laura was ill for a long time, but she recovered; she had that resolution in her that could conquer death almost. And with her health came back her beauty, and an added fascination, a something that might be mistaken for sadness. Is there a beauty in the knowledge of evil, a beauty that shines out in the face of a person whose inward life is transformed by some terrible experience? Is the pathos in the eyes of the Beatrice Cenci from her guilt or her innocence?

Laura was not much changed. The lovely woman had a devil in her heart. That was all.

